



# Installation Guide

*For DC Electric Windlass Models*

**MIDI 203**



**SLEIPNER MOTOR AS**

P.O. Box 519

N-1612 Fredrikstad

Norway

[www.sleipnergroun.com](http://www.sleipnergroun.com)

**DOCUMENT ID: 7092**

**REVISION: 5**

**DATE: 2023**

**LANGUAGE: EN**

**MI**

# Contents

## Installation Manual

Responsibility of the Installer.....	3
General Installation Consideration and Precaution Guidelines .....	3
Product Measurements .....	4
Product Specifications .....	5
Installation Preparation .....	6
Anchor Line Clearance .....	7
Windlass Mounting Installation .....	8
Windlass Electrical Installation .....	9
Visual Wiring Diagram .....	11
Configuring Windlass Type.....	12
Fault Codes .....	12
Windlass Circuit Breaker .....	13
Insert Anchor Line Into The Windlass Line Wheel .....	14
Anchor Line Around The Line Wheel .....	15
Anchor Line Stop Rings for Auto Stop .....	16
Anchor Line Stop Ring Installation .....	17
Pre-delivery Checklist .....	18
<b>Service and Support.....</b>	<b>19</b>
<b>Product Spare Parts and Additional Resources.....</b>	<b>19</b>
<b>Warranty Statement.....</b>	<b>19</b>
<b>Patents.....</b>	<b>19</b>



Sleipner Motor AS  
P.O. Box 519, Arne Svendsensgt. 6-8  
N-1612 Fredrikstad, Norway

MC\_0451

## Responsibility of the Installer

The installer must read this document to ensure necessary familiarity with the product before installation.

Instructions in this document cannot be guaranteed to comply with all international and national regulations. It is the responsibility of the installer to follow all applicable international and national regulations when installing Sleiþner products.

The recommendations given in this document are guidelines ONLY, and Sleiþner strongly recommends that advice is obtained from a person familiar with the particular vessel and applicable regulations.

This document contains general installation instructions intended to support experienced installers. If you are not skilled in this type of work, please contact professional installers for assistance.

If required by local regulation, electrical work must be done by a licensed professional.

Appropriate health and safety procedures must be followed during installation.

Faulty installation of Sleiþner products will render all warranties given by Sleiþner Motor AS.

Ensure appropriate access to Sleiþner products during installation planning for service, inspection and component replacement.

## General Installation Consideration and Precaution Guidelines

### For Windlass systems

Never use a windlass close to somebody in the water, an unexpected drop of the anchor can cause serious injuries.

It is the owner/ captain/ other responsible parties full responsibility to assess the risk of any unexpected incidents on the vessel.

- Keep your distance to the windlass, the anchor line, anchor and anchor brackets during operation.
- While operating the anchor maintain observation of the rope or chain during handling.
- Ensure anyone using the windlass knows how to operate it.
- Be aware when the anchor are raised as it can bring unwanted debris up from the bottom, potentially damaging your boat. **(NB: If the windlass is straining as the anchor is raised, stop for a few seconds and let the boat gain up momentum before continuing the raise.)**
- If the anchor is stuck, release some anchor line/chain and attach it to a cleat before using the boat to pull the anchor free. The windlass is not designed for loads beyond the specified pull capabilities.
- The anchor MUST ALWAYS be secured to the boat while under way. Use the security line or other means to prevent unintentional anchor drop.
- Children must not operate the windlass.
- Careless use can cause damage or injury!
- Keep the engine running during windlass operation to ensure good battery capacity.
- Sleiþner Motor AS is not responsible for damage or injury caused by the use of our windlass systems.
- While dropping anchor, do not push the "UP" button until the anchor is resting at the seabed.

### For MIDI windlass systems

Sleiþner MIDI is designed for boats up to approximately 7 meters. These windlasses are true free-fall windlasses and are developed with an electrical control unit. This unit is ready for connecting Sleiþner remote control and switch panel.

Ensure there is sufficient weight from the anchor when the windlass is released. The pulling force must overcome any friction/ weight of the anchor line and pulley system.

Measurement code	Measurement description	MIDI	
		mm	inch
H	Total Height	329	13
W	Total width	151.5	6
L	Total length	174.4	7
(a)	Motor diameter	90	3.5
(b)	Motor bracket attachment measurements	30.1	1.2
(c)	Motor bracket attachment diameter	13	0.5
(d)	Motor bracket attachment diameter	9	0.35
(e)	Motor bracket attachment measurements	12	0.5
(f)	Motor bracket attachment measurements	15	0.6
(g)	Motor bracket attachment diameter	36	1.4
(h)	Motor bracket attachment measurements	35	1.4
(i)	Motor bracket attachment measurements	143	5.6
(j)	Motor bracket attachment measurements	65.4	2.6
(k)	Motor bracket attachment measurements	70	2.8
(l)	Motor bracket attachment measurements	100	3.9

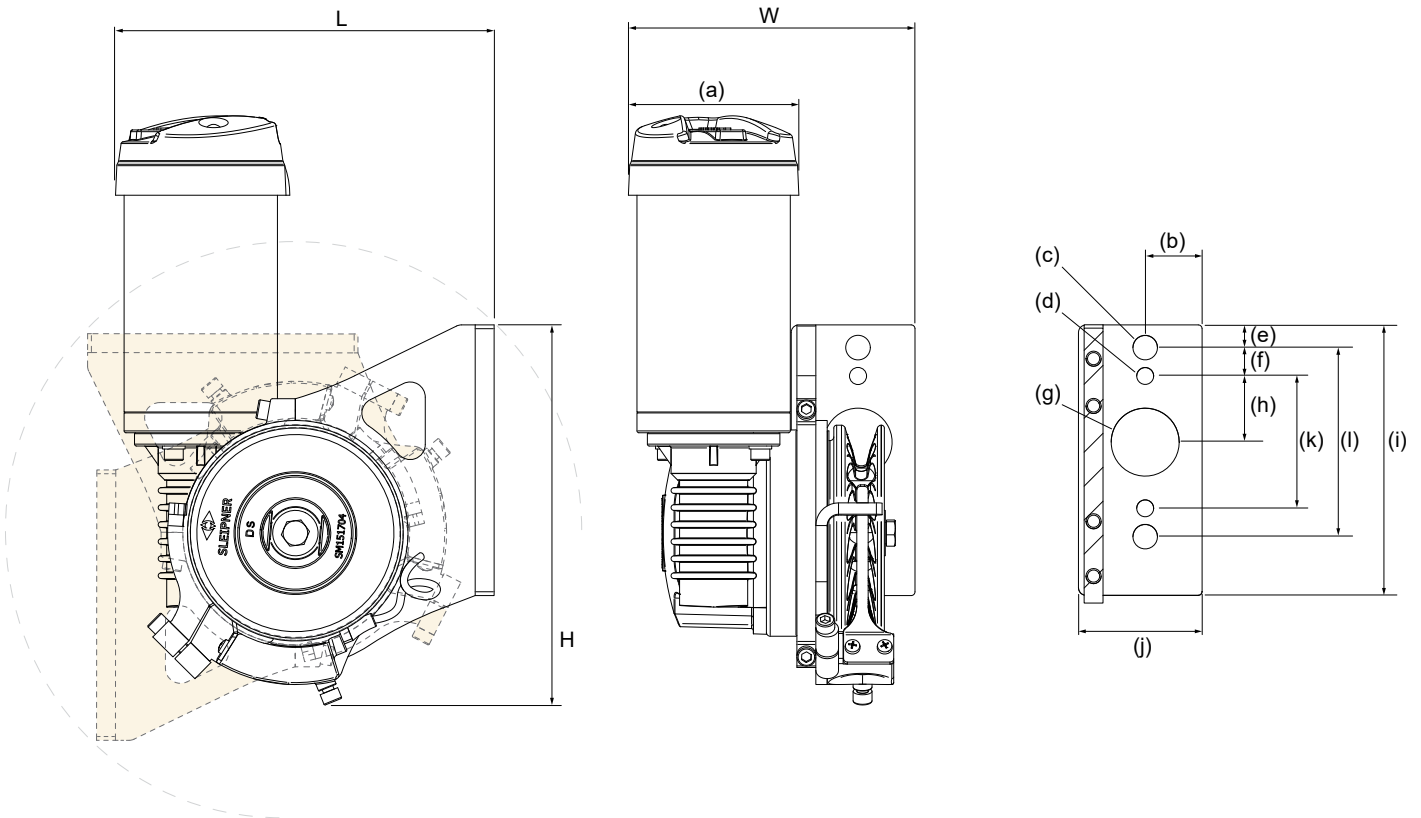

Description	MIDI 203
Maximum Operating Voltage	12v
No-Load current (V)	<0.1A with 12v
Power Consumptions	10-200A approx 40A with 30kg load
Typical Boat Size (m / ft)	< 7m / <25ft
Pulling power (Electronically governed)	Up to 200kg
Pulling speed	15-30m/min approx 20m/min with 30kg load
Weight kg / lbs	9.8 kg / 21.6 lbs
Anchor Weight (Recommended)	5 to 15 kg
Motor	Custom made PMDC motor
Line	Braided lead line diameter 12 mm. Breaking load: 1600 daN
Auto Stop	Yes
Minimum Battery Capacity	12v/ 75Ah

**Equipment:**

- Anchor (Multiple types)
- Anchor bracket (Multiple types)
- Lead line (MIDI)
- Thru-Hull conduit for rope anchor line
- Remote control
- Control panel
- Cables
- Control box unit
- Main Switch with fuse

## IMPORTANT

- Ensure to have all necessary tools ready
- Unpack and organize all components
- Prepare and control the areas where all the different parts can be mounted.
- Follow the mounting instructions
- When winching the rope for the first time after mounting, make sure the rope is tight, so the rope is pulled in correctly.

### Placing the parts

You must plan the placement of the following parts:

- |                                    |                                |                 |
|------------------------------------|--------------------------------|-----------------|
| 1-Motor                            | 4-Control-box                  | 7-Control panel |
| 2-Thru-Hull conduit                | 5-Cables                       |                 |
| 3-Brackets for anchor and windlass | 6-Main switch/ circuit breaker |                 |

### General

The windlass should be positioned as high as possible in its installation area to allow maximum space for the anchor line that is stored below the windlass.

**(NB: Remember to attach the end of the anchor line somewhere inside the boat.)**

### Anchor bracket

Ensure the windlass and the anchor bracket keep the anchor line straight during operation. – Numerous different models are available. The anchor bracket is working as a guide for the rope when the anchor is on the seabed and as a “seating point” for the anchor once it has been raised.

### Platform roller or hinged platform roller

If the windlass is fitted low in relation to the anchor roller, so the angle between the anchor roller and hull conduit is small, use an Sleiþner hinged platform roller or a pivoting platform roller with spring «62-30000» to ensure that the free-fall will work. Ensure the anchor line is wound up in-line with the hull conduit.

### Hull conduit / Line guide

Install a Sleiþner specific hull conduit that guides the anchor line with low friction through the hull.

### Anchor line

Use a Sleiþner specific woven anchor line with a lead core. It is supplied in 30 and 50 meter lengths from Sleiþner.

### Safety line

Once the anchor is seated in the anchor bracket, it must be secured with the safety line.



Anchor line

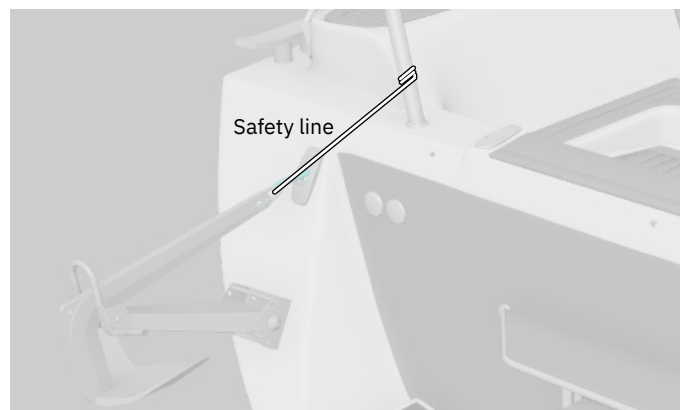
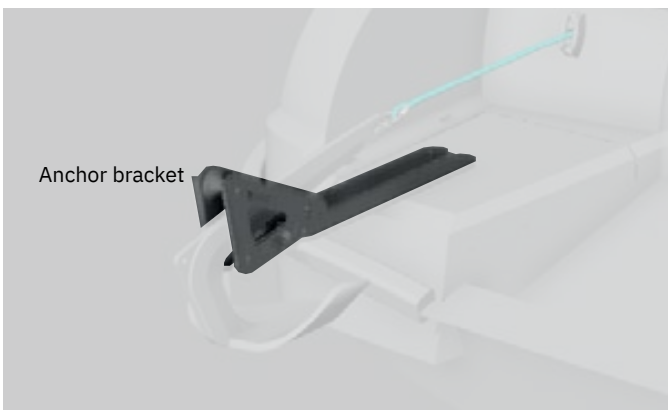

In order for the windlass to function normally, there must be a sufficient volume/ height below the windlass for stowing the anchor line when the anchor is up.

**Recommended minimum height (A) below the windlass as well as width (B) and length (C) of the area used for stowing the anchor line.**

Anchor Line.	A (cm)	B (cm)	C (cm)
12 mm x 30 m	35	30	30
12 mm x 50 m	40	35	35

**IMPORTANT**

In case of installations where the anchor line is routed horizontally out of the windlass when the anchor is up, the relationship between A, B and C may vary. It is important that there is a sufficient volume to ensure that the anchor line is not forced into place below the windlass and cannot easily be pulled out by the line wheel.

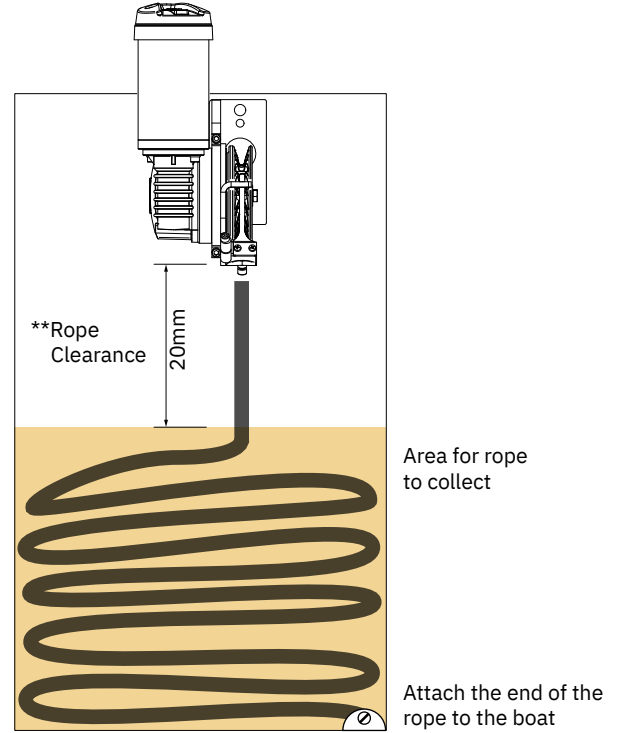
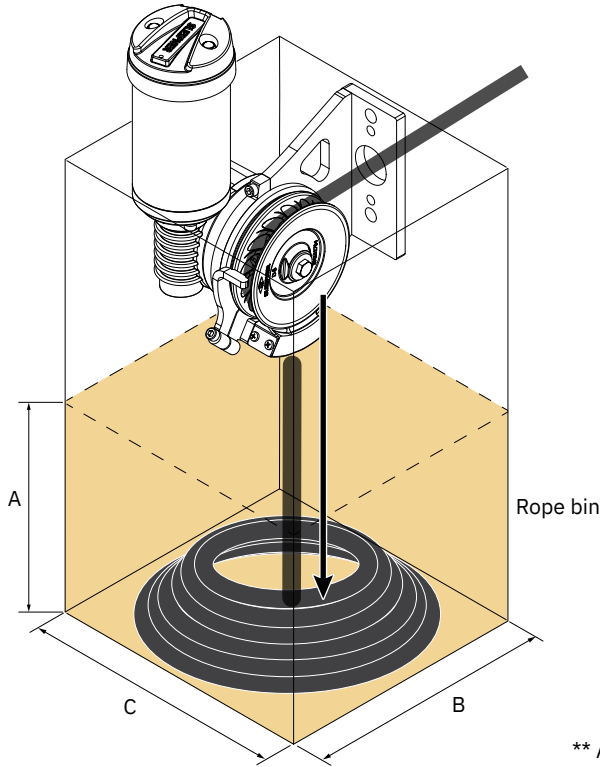

\*\* A low rope clearance will cause rope jamming and spinning when reeling in the anchor line.

## Mounting

- The mounting bracket for MIDI allows for infinitely variable rotation in relation to the windlass gear leg/motor.
  - The bracket for the anchor line guide and stop sensor can also be rotated independently of the gear leg/ motor and mounting bracket.
  - This allows for installing the windlass on surfaces with different angles in relation to the stern. It can be fitted on the inside of the stern, hanging below the deck or aft of cross bulkheads inside the boat.
1. Position the windlass mounting bracket by loosening the two screws fastening the bracket to the gear housing, rotate the windlass to the correct position and tighten the screws. **(NB: Max. tightening torque 17 Nm.)**
  2. Adjust the windlass anchor line guide and stop sensor in a corresponding manner by loosening the screw fastening it to the gear leg. Rotate the bracket so the anchor line is guided down and away from bulkheads and components that prevent the anchor line from coiling correctly below the windlass. **(NB: Max. tightening torque 17 Nm.)**

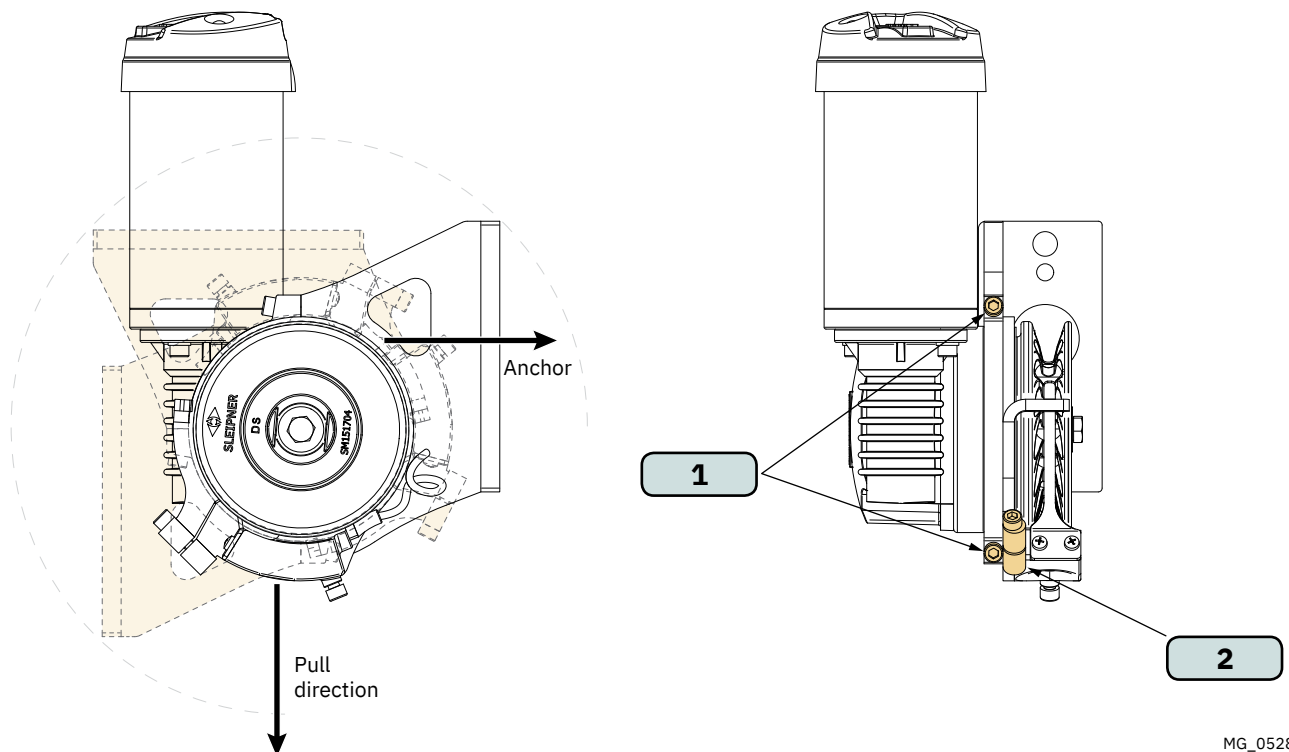

MG\_0528



**! Please refer to the graphic for special considerations relating to your model !**

All kind of wiring and electrical fixing must be done with Main switch/ miniature circuit breaker turned OFF and no battery cables attached.

**1. Connecting switch panel 86-08950 or 86-08955**

- 4-way Sleipner cable come in various lengths.
- 4-way Sleipner cable are easy attached to contacts on control box unit (150810).
- The cable must be attached to 150810 contact unit.
- See wiring diagram or control panel manuals for more details.
- Multiple panels can be fixed to the same control unit.

**2. Connecting the auto stop sensor**

Cables are connected like this:

- : Brown (BN)
- : Black (BK)
- : Blue (BU)

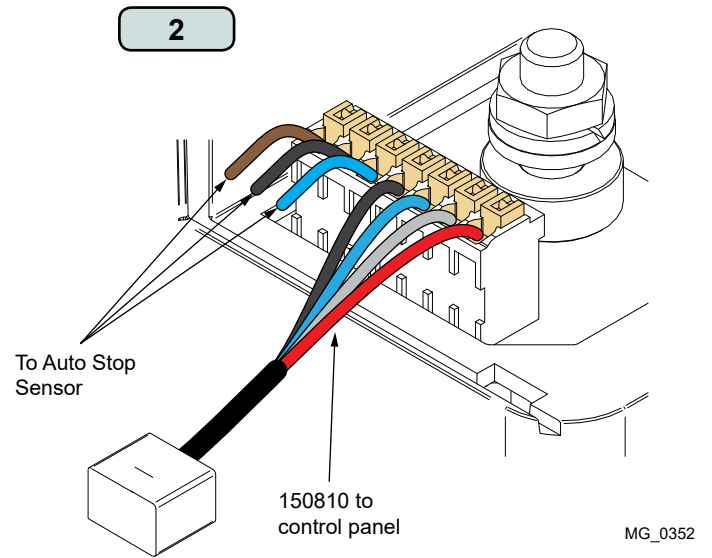
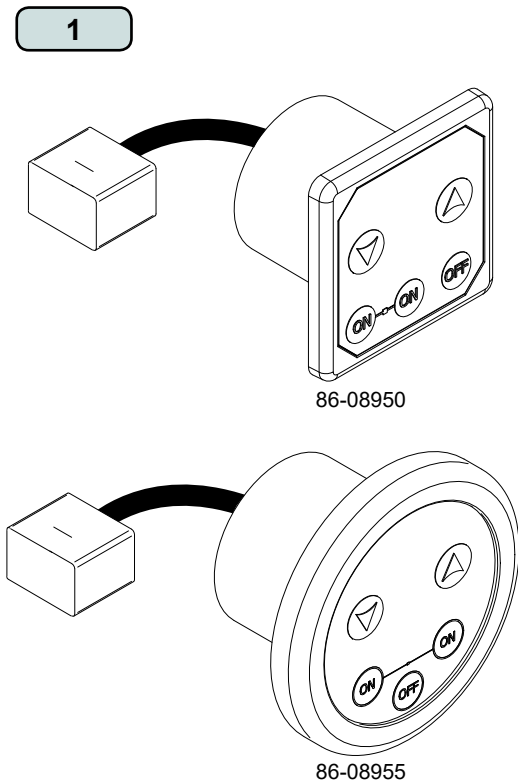

**! Please refer to the graphic for special considerations relating to your model !**

## Fitting control unit 150800

The unit is not water resistant or splash proof and must be placed in a dry area close to the windlass motor.

Use M6 terminals for the selected battery cables.

Tighten the terminals to maximum 5Nm.

Pay attention to assemble the terminal spacers and washers in the correct order according to figure 1.

The unit has mounts that ensures space between the unit and it's mounting surface. This to avoid condensation to enter the unit. It also ensures proper ventilation of the enclosure.

The control unit must be mounted with the cables protruding downwards.

## Connecting the motor and battery cables on Midi

Motor for windlass type Midi is delivered with cables fitted to the motor.

- Fit included copper link(A1-A2 LINK) between Terminal A1 and A2.
- Connect the red cable from the motor to the Terminal marked D1/M+.
- Connect the black cable from the motor to the Terminal marked D2/M-.
- Connect supply cable from battery negative to the Terminal marked B-.
- Connect supply cable from breaker/ fuse to the Terminal marked B+.
- Connect breaker/ fuse to battery main switch.
- See complete *wiring diagram* in this manual for reference.
- Tighten all terminals properly, including A1 and A2, with a maximum torque of 5Nm. Over-tightening may damage the terminals.
- Leave breaker/fuse disconnected until the installation is completed.

See control unit (150800) manual for configuring programming and more installation information.

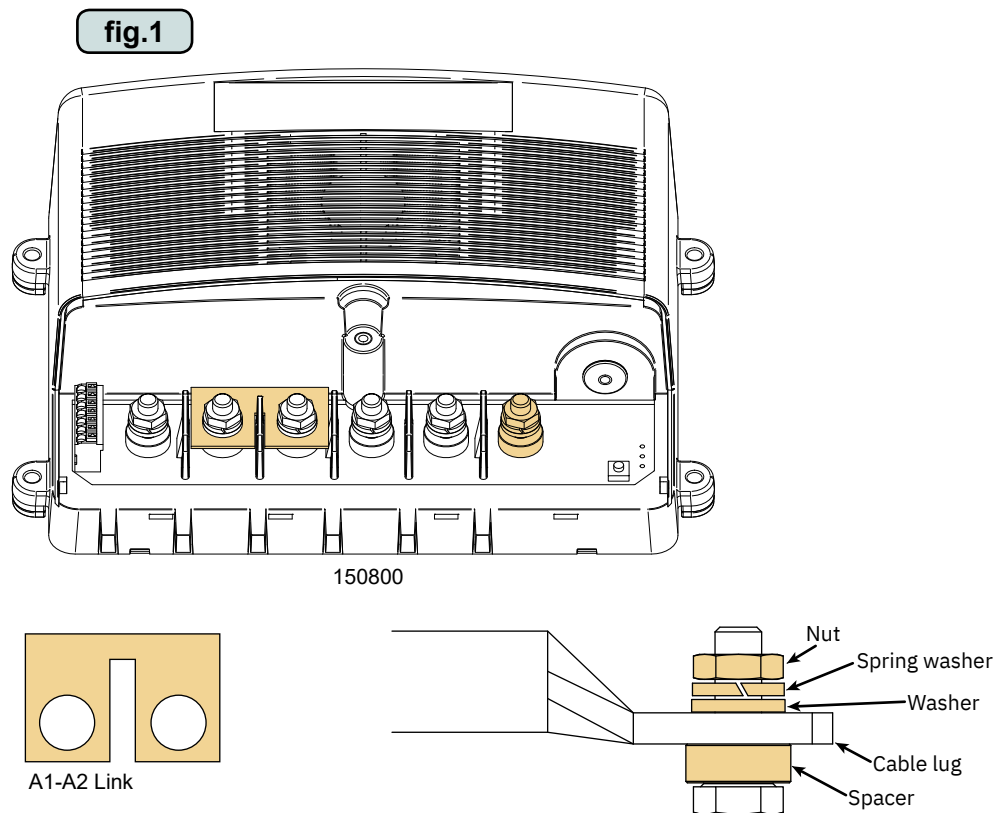

# Visual Wiring Diagram

## Cable size A, B and C:

if total length

A+B+C <10m: 25mm<sup>2</sup>

A+B+C >10m: 35mm<sup>2</sup>

## To change motor direction:

Change cables D1 and D2 in control unit

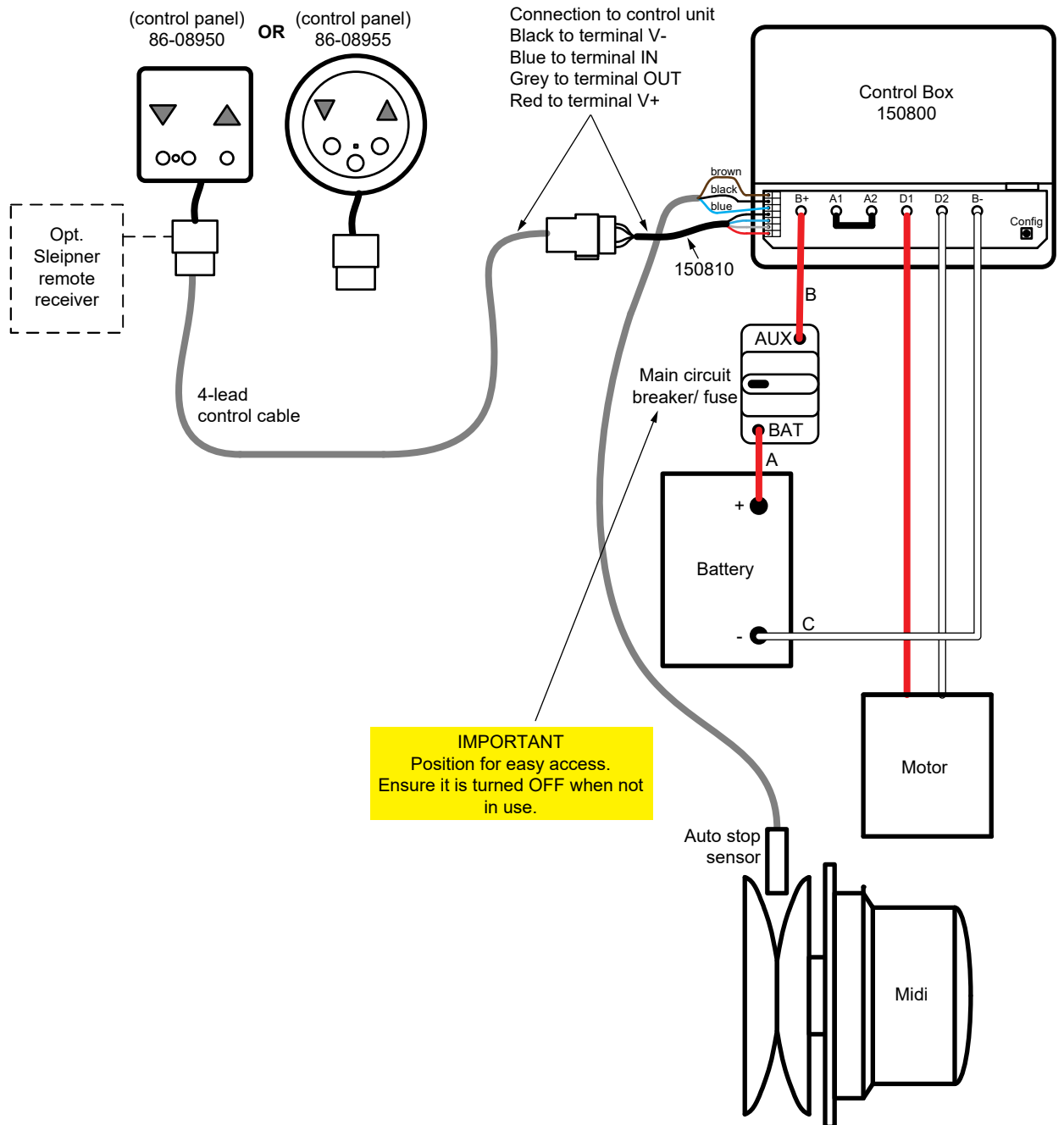

1. Press and hold “Config” button for 3 seconds, until Power and Fault LED starts blinking.
2. Press “Config” button to cycle through types, until the Mode LEDs show the correct pattern.
3. The controller returns to normal operation after 3 seconds of inactivity.
4. Verify that the pattern shown is correct. This description can also be found on the back of the terminal covers.

**Configure windlass type**

**1: Press and hold "Config" button for 3 seconds, until Power and Fault LED starts blinking.**

**2: Press "Config" button to cycle through types, until the Mode LEDs show the correct pattern.**

**3: The controller returns to normal operation after 3 seconds of inactivity.**

Mode LED	NOT SET	MINI ROPE	MIDI ROPE	MAXI ROPE	MAXI CHAIN	MHPP ROPE
1	●	○	○	○	○	○
2	●	○	○	○	○	○
3	●	○	○	○	○	○

**NOT SET**

Press and hold “Config” button for 3 seconds, until Power and Fault LED starts blinking.

**MINI ROPE**

Configuration set for using a MINI windlass utilizing a rope anchor lead.

**MIDI ROPE**

Configuration set for using a MIDI windlass utilizing a rope anchor lead.

**MAXI ROPE**

Configuration set for using a MAXI windlass utilizing a rope anchor lead.

**MAXI CHAIN**

Configuration set for using a MAXI windlass utilizing a chain anchor lead.

.....

**MHPP ROPE**

Configuration set for using a MHPP designed for specific installations.

**If not required the MHPP configuration can damage the windlass system.**

## Fault Codes

**“Fault” LED is lit:**

The last fault condition detected by the controller is indicated by the “Mode” LEDs, visible when the terminal cover is removed. Some faults will inhibit operation, while others allow continued use. See Troubleshooting table.

**Fault Codes**

**If the "Fault" LED is lit, the last fault condition is indicated by the "Mode" LEDs.**

**Consult User Manual for complete fault descriptions.**

Mode LED	Low Voltage	Motor Overload	Controller Overtemp	Motor Overtemp	Controller Overload	Runtime Exceeded
1	●	○	○	○	○	○
2	○	○	○	○	○	○
3	○	○	○	○	○	○

**Main switch and circuit breaker**

119-00015(Midi 150A)

- MUST be used at all time in this installation
- Works as both MCB and main switch unit.
- The unit consists of one battery connection and one AUX connection. This is described on the unit. See wiring diagram for correct connection to battery and control box.
- Unit switched ON
  - To switch ON, move/press pin switch upwards.
- Unit switched OFF.
  - To switch OFF, press red the button.

**WARNING**

Improper use or incorrect connection of such high currents components will generate a lot of heat which in worst case can cause fire.

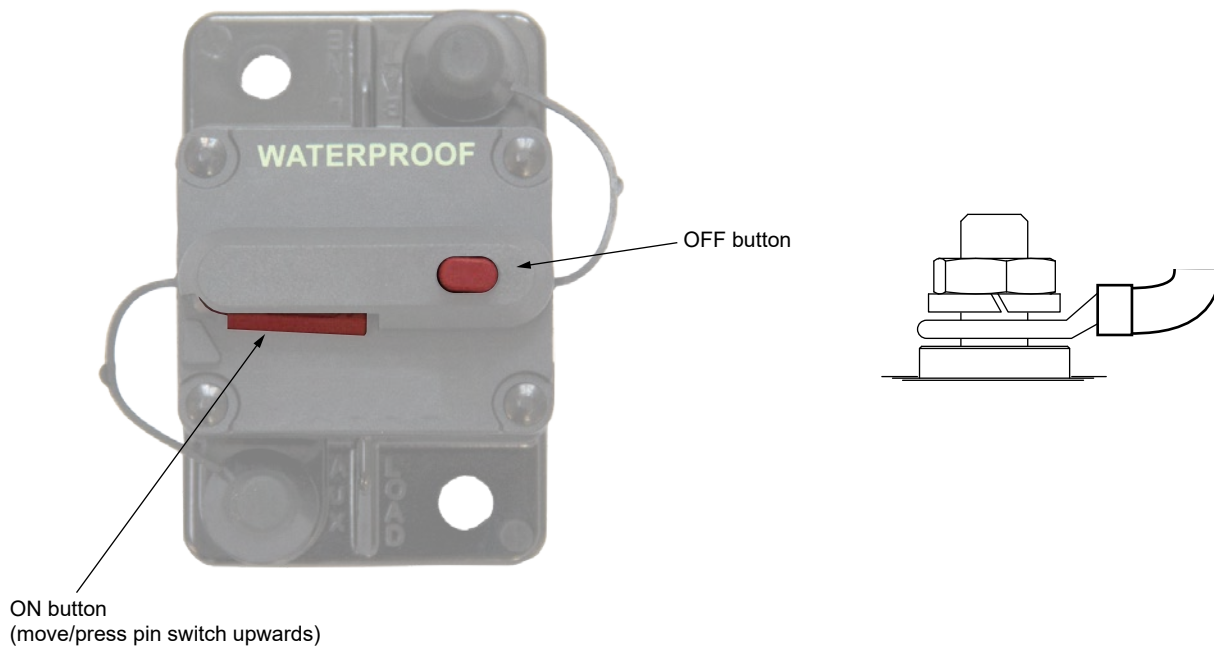

MG\_0354

1. Insert the anchor line into the gypsy wheel between the wheel and the anchor line guide. It may be easier if you bend the tip of the anchor line guide tab carefully.
2. Route the anchor line via the gypsy wheel and out through the hole in the anchor line deflector. When the tip of the anchor line has been pulled through the anchor line deflector, the rest of the anchor line can be pulled through using the windlass. Ensure the windlass gypsy reels as intended.

### IMPORTANT

When pulling in the anchor line for the first time, you must keep the anchor line tight, so the anchor line run correctly.  
Be careful to avoid injuring fingers.

Secure the end of the anchor line to an appropriate point after threading it through the windlass.

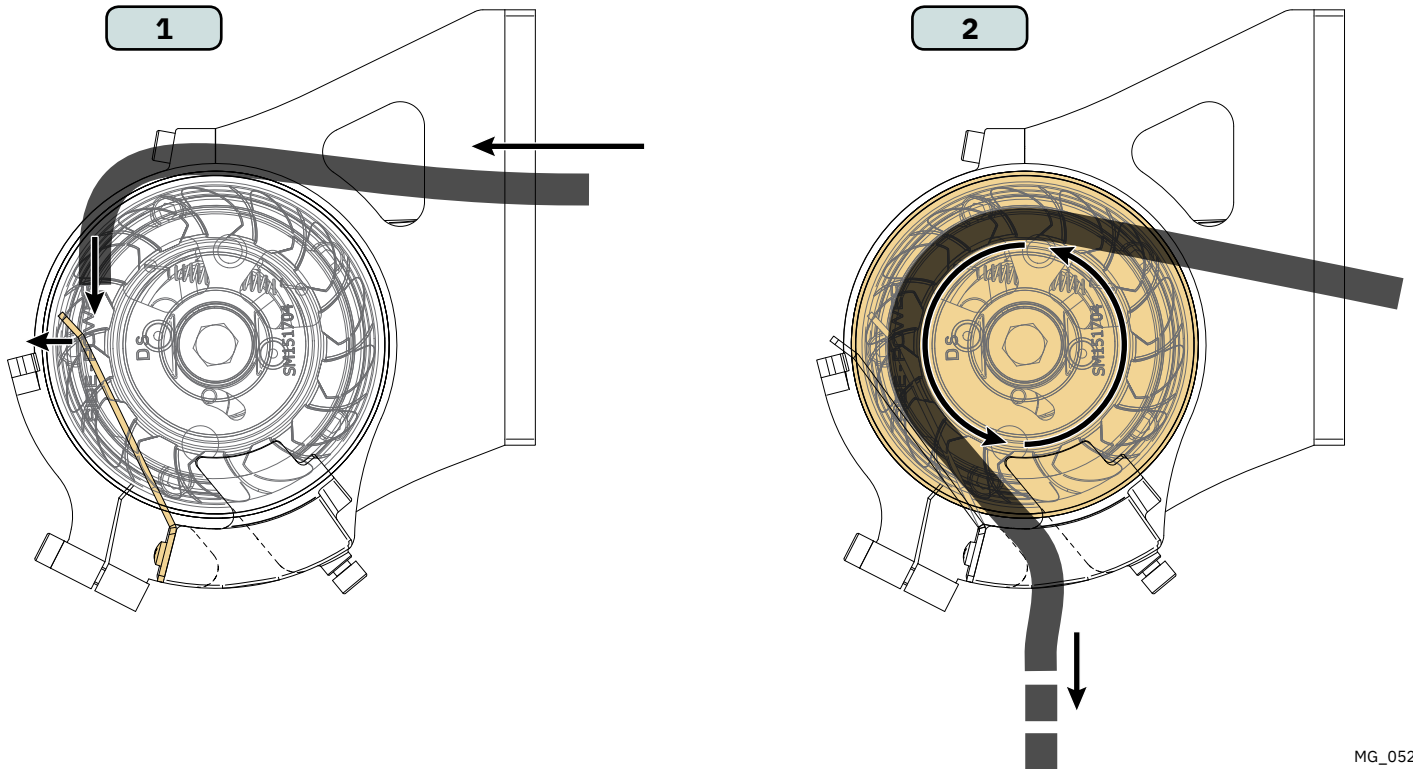

MG\_0529

# Anchor Line Around The Line Wheel

Windlass on a vertical cross bulkhead, on the inside of the stern.

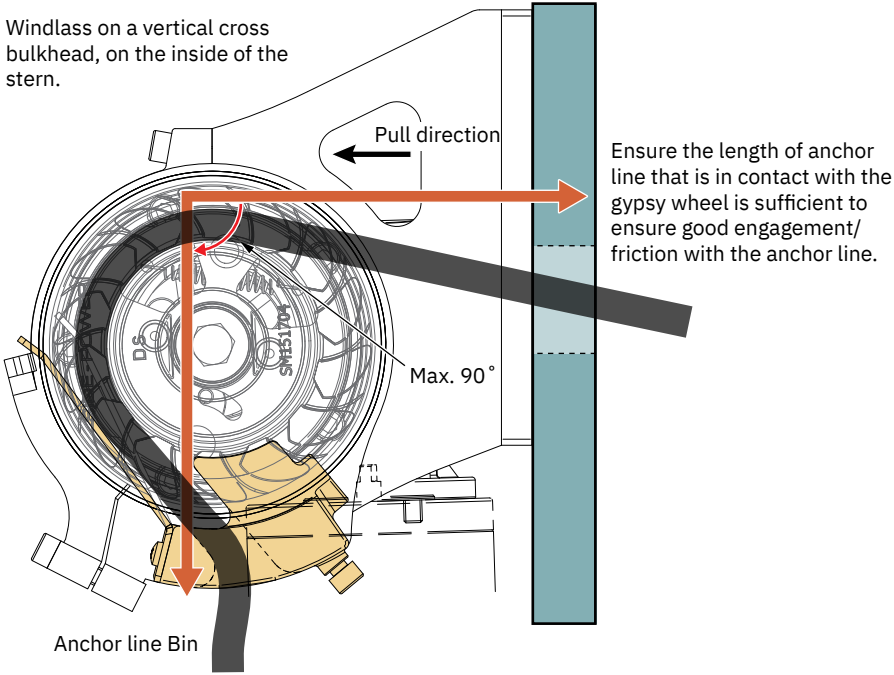

The mounting bracket for MIDI 202 allows for infinitely variable rotation with the windlass gear leg/ motor.

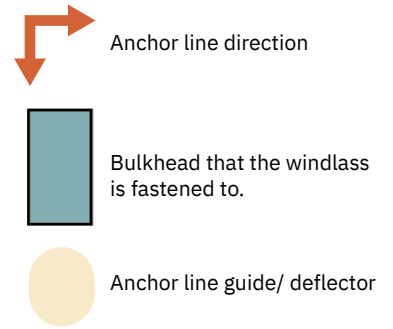

**IMPORTANT**  
 Regardless of how the windlass is fastened to the boat, the angle between where the anchor line enters and leaves the gypsy wheel must be maximum 90 degrees.

Ensure there is sufficient room to stow the anchor line below and next to the windlass.

When pulling in the anchor line for the first time, you must keep the anchor line tight, so it runs correctly.

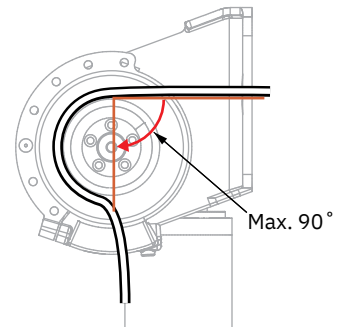
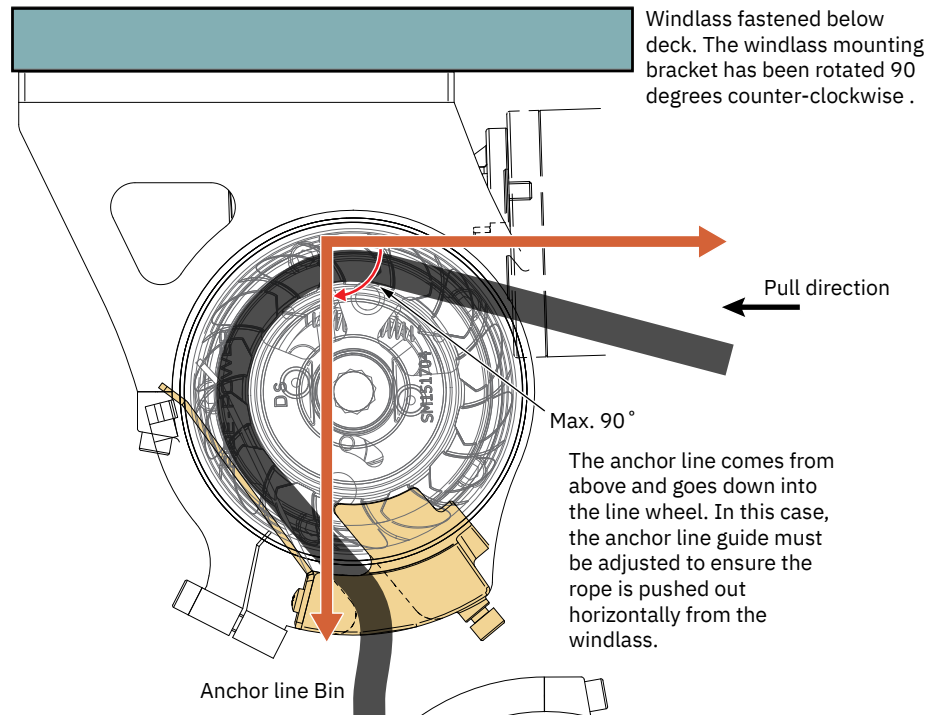

**IMPORTANT**  
 Ensure the anchor line travels around the gypsy to allow the teeth to catch the anchor line.

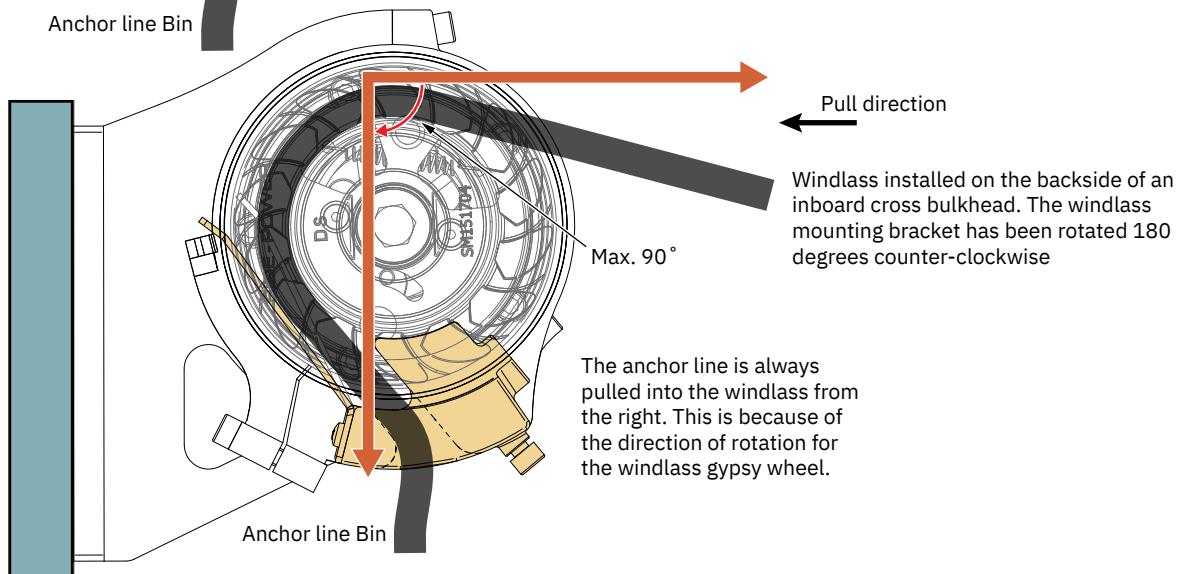

## IMPORTANT

The anchor line guide includes an inductive sensor that signals auto stop when the anchor has been lifted all the way up. To activate the detector, two stop rings (included) are fitted on the anchor line. The outer diameter of the stop ring must be as close to the outer diameter of the anchor line as possible. This is necessary in order for the inductive detector to be able to detect correctly.

To place the stop ring at the correct location on the anchor line:

1. Lift the anchor until the thimbal eye is 25-50 cm below the anchor line roller and mark the anchor line with a marker at the location of the inductive sensor.
2. Reel in at low speed by double clicking the windlass up button to the final resting position and mark the anchor line one more at the location of the inductive sensor. Mark the anchor line once more by the detector and fasten the stop rings by the marks.

These stop rings will be exposed to wear by the line wheel, especially during heavy loads, and must therefore be inspected regularly. Replace damaged stop rings if needed.

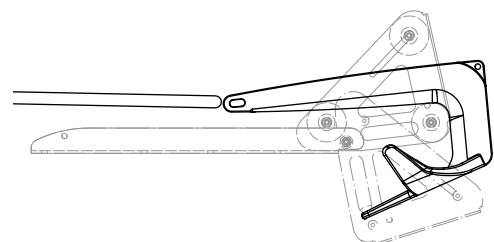
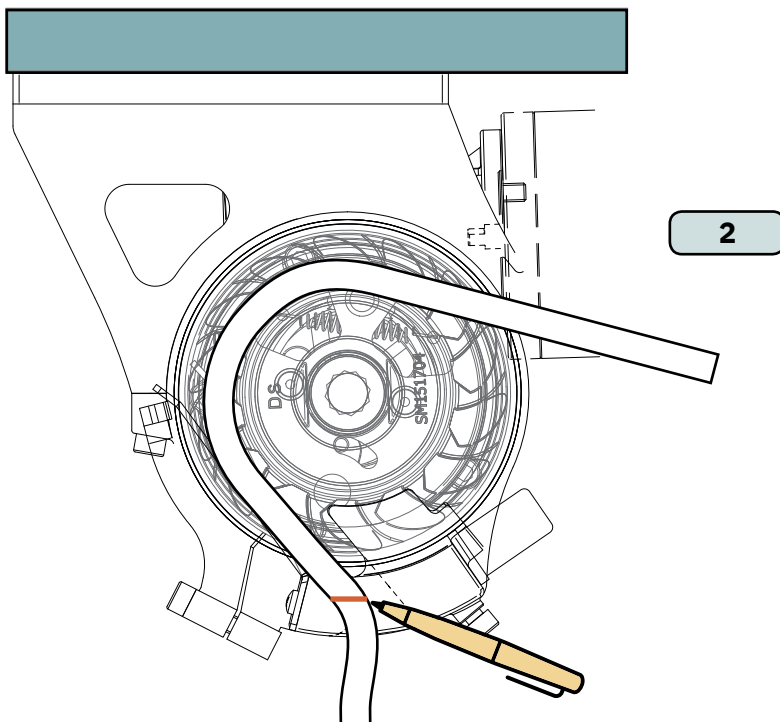
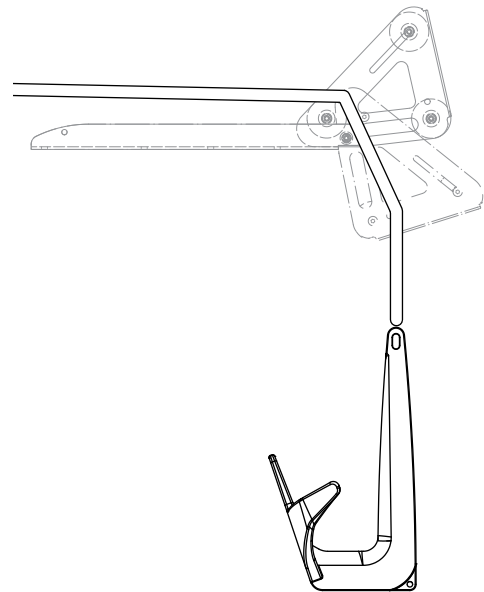
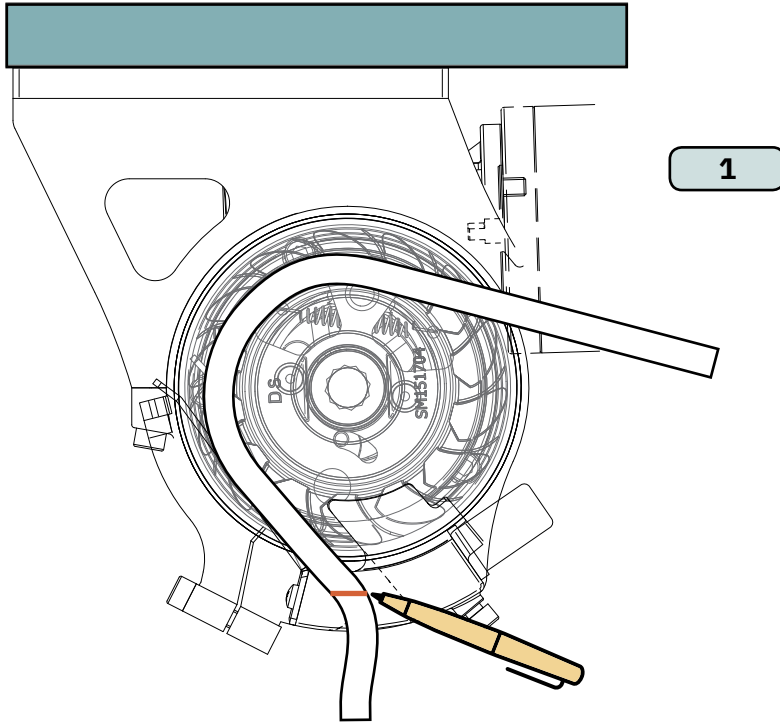



The enclosed steel rings (auto stop rings) are fitted in the locations where the windlass should slow down and then come to a full stop.

1. Open the stop rings with the pliers.
2. Fit the ring over the anchor line. Use the pliers to pull the stop ring into place with the stop ring joint overlapping the opening and the ring fitted tightly around the anchor line.
3. Force the ends into the anchor line with the pliers to ensure the stop ring does not slip on the anchor line. **(NB: A fitted stop ring should look like this with closed windings and the ends secured inside the anchor line.)**
4. Stop ring fitted and fastened tightly to the anchor line. Fasten the other stop ring in the same manner.

Recommended tools:  
Keeper ring pliers  
Pliers

Stop Rings for Auto Stop



Pliers

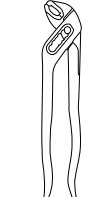

Water pump pliers



Auto stop rings

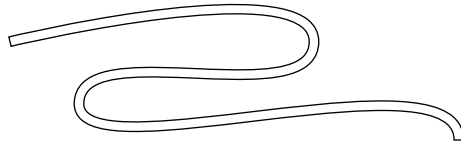

Anchor line

1



2

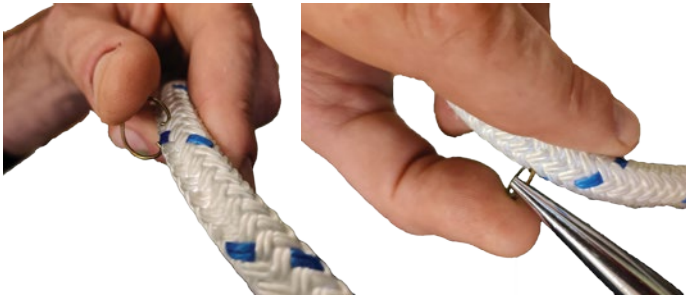

3

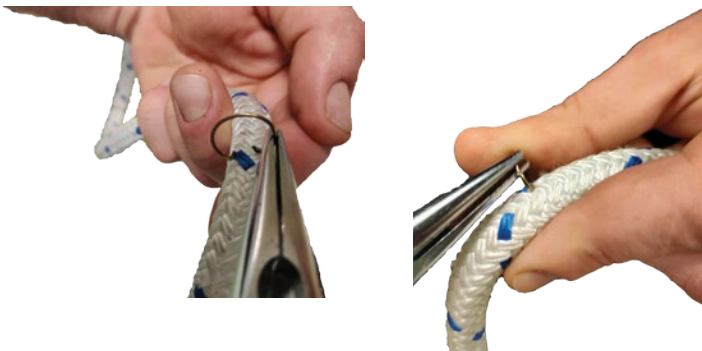
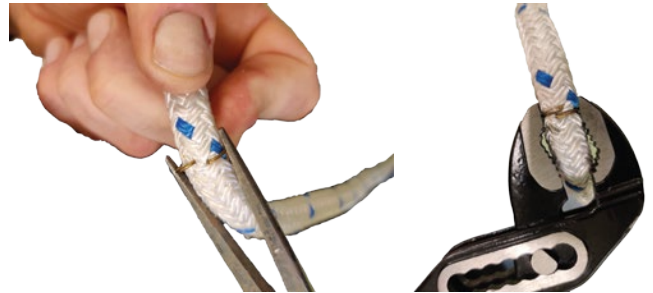

MG\_0350

- ..... The bolts holding the windlass to the hull are tightened.
- ..... All bolts holding the windlass components are tightened.
- ..... 2 x stop rings are attached to the anchor line.
- ..... Control unit (150800) terminal cables are tightened and configured for your product.
- ..... 'OUT' button runs the motor for approx. 2 sec, 'IN' button runs the motor constantly.
- ..... The end of the anchor line is attached to the boat.
- ..... Anchor safety line is in place and adjusted.

The Windlass has been installed as per the instructions in this manual and all points in checklist above have been controlled.

Signed: .....

Date: .....

Motor type: .....

Serial number:.....

Date of delivery:.....

The compartment for the product has been isolated from general bilge water and has no obvious or suspected risks for flooding:

.....  
.....  
.....

Other comments by installer: .....

.....  
.....  
.....

**Find your local professional dealer from our certified worldwide network for expert service and support. visit our website [www.sleipnergrouper.com/support](http://www.sleipnergrouper.com/support)**

## Product Spare Parts and Additional Resources

**For additional supporting documentation, we advise you to visit our website [www.sleipnergrouper.com](http://www.sleipnergrouper.com) and find your Sleipner product.**

## Warranty statement

1. Sleipner Motor AS (The “Warrantor”) warrants that the equipment (parts, materials, and embedded software of products) manufactured by the Warrantor is free from defects in workmanship and materials for purpose for which the equipment is intended and under normal use and maintenance service (the “Warranty”).
2. This Warranty is in effect for two years (Leisure Use) or one year (Commercial and other Non-leisure Use) from the date of delivery/purchase by the end user, with the following exceptions;
  - (a) For demonstration vessels, or vessels kept on the water, the dealer is considered as the end user from 6 months after their launch of the vessel;
  - (b) The warranty period starts no later than 18 months after the first launch of the vessel.
 Please note that the boat manufacturer and dealer must pay particular attention to correct maintenance and service both by the products manuals as well as general good practice for the location the boat is kept in the period the boat is in their care. In cases where the 6 and 18 months grace periods for boat builders and dealers are passed, it is possible to obtain a full warranty upon inspection and approval of the warrantor or such representative.
3. Certain parts, classified as wearable or service parts, are not covered by the warranty. A failure to follow the required maintenance and service work as described in the product manual render all warranty on parts or components directly or indirectly affected by this void. Please also note that for some parts, time is also a factor separately from actual operational hours.
4. This Warranty is transferable and covers the equipment for the specified warranty period.
5. The warranty does not apply to defects or damages caused by faulty installation or hook-up, abuse or misuse of the equipment including exposure to excessive heat, salt or fresh water spray, or water immersion except for equipment specifically designed as waterproof.
6. In case the equipment seems to be defective, the warranty holder (the “Claimant”) must do the following to make a claim:
  - (a) Contact the dealer or service centre where the equipment was purchased and make the claim. Alternatively, the Claimant can make the claim to a dealer or service centre found at [www.sleipnergrouper.com](http://www.sleipnergrouper.com). The Claimant must present a detailed written statement of the nature and circumstances of the defect, to the best of the Claimant’s knowledge, including product identification and serial nbr., the date and place of purchase and the name and address of the installer. Proof of purchase date should be included with the claim, to verify that the warranty period has not expired;
  - (b) Make the equipment available for troubleshooting and repair, with direct and workable access, including dismantling of furnishings or similar, if any, either at the premises of the Warrantor or an authorised service representative approved by the Warrantor. Equipment can only be returned to the Warrantor or an authorised service representative for repair following a pre-approval by the Warrantor’s Help Desk and if so, with the Return Authorisation Number visible postage/shipping prepaid and at the expense of the Claimant.
7. Examination and handling of the warranty claim:
  - (a) If upon the Warrantor’s or authorised service Representative’s examination, the defect is determined to result from defective material or workmanship in the warranty period, the equipment will be repaired or replaced at the Warrantor’s option without charge, and returned to the Purchaser at the Warrantor’s expense. If, on the other hand, the claim is determined to result from circumstances such as described in section 4 above or a result of wear and tear exceeding that for which the equipment is intended (e.g. commercial use of equipment intended for leisure use), the costs for the troubleshooting and repair shall be borne by the Claimant;
  - (b) No refund of the purchase price will be granted to the Claimant, unless the Warrantor is unable to remedy the defect after having a reasonable number of opportunities to do so. In the event that attempts to remedy the defect have failed, the Claimant may claim a refund of the purchase price, provided that the Claimant submits a statement in writing from a professional boating equipment supplier that the installation instructions of the Installation and Operation Manual have been complied with and that the defect remains.
8. Warranty service shall be performed only by the Warrantor, or an authorised service representative, and any attempt to remedy the defect by anyone else shall render this warranty void.
9. No other warranty is given beyond those described above, implied or otherwise, including any implied warranty of merchantability, fitness for a particular purpose other than the purpose for which the equipment is intended, and any other obligations on the part of the Warrantor or its employees and representatives.
10. There shall be no responsibility or liability whatsoever on the part of the Warrantor or its employees and representatives based on this Warranty for injury to any person or persons, or damage to property, loss of income or profit, or any other incidental, consequential or resulting damage or cost claimed to have been incurred through the use or sale of the equipment, including any possible failure or malfunction of the equipment or damages arising from collision with other vessels or objects.
11. This warranty gives you specific legal rights, and you may also have other rights which vary from country to country.

## Patents

At Sleipner we continually reinvest to develop and offer the latest technology in marine advancements. To see the many unique designs we have patented visit our website [www.sleipnergrouper.com/patents](http://www.sleipnergrouper.com/patents)

© **Sleipner Group**, All rights reserved  
The information given in the document was right at the time it was published. However, Sleipner Group cannot accept liability for any inaccuracies or omissions it may contain. Continuous product improvement may change the product specifications without notice. Therefore, Sleipner Group cannot accept liability for any possible differences between product and document.

**Learn more about our products at**  
**[www.sleipnergroun.com](http://www.sleipnergroun.com)**



**SLEIPNER GROUP**

P.O. Box 519

N-1612 Fredrikstad

Norway

[www.sleipnergroun.com](http://www.sleipnergroun.com)

Made in Norway

