



Installation Guide

For Pro Ignition Protected DC Thruster Models
SEP-IP30, SEP-IP40



SLEIPNER MOTOR AS

P.O. Box 519
N-1612 Fredrikstad
Norway
www.sleipnergroun.com

DOCUMENT ID: 5468

REVISION: I5

DATE: 2024

LANGUAGE: EN



Contents

Warnings and Safety	2
Responsibility of the Installer	3
Installation Manual	
Ignition Protection	4
Product Dimensions	5
Product Clearance Requirements	6
Product Specifications	6
Proportional Technical Specifications	6
Positioning of the tunnel / thruster	7
Tunnel Length	8
Tunnel installation in sail boats	9
Water Deflection	10
Tunnel ends	11
Tunnel installation	12
Stern tunnel installation	14
Gear Leg & Motor Bracket Installation	15
Propeller Installation	18
Motor Installation	19
Electrical Installation	20
Product Lug Connection Configuration	21
Electrical Reference Guide	21
Manual Main Switch Wiring Diagram 12V S-Link IP Thruster	22
Automatic Main Switch Wiring Diagram 12V S-Link IP Thruster	23
S-Link System Description	24
Control Panel Installation	25
Pre-delivery Checklist	26
Service and Support	27
Product Spare Parts and Additional Resources	27
Warranty Statement	27

Warnings and Safety

MC_0800

It is essential to follow all information within this document to avoid potential personal injury, death, and/or damage to your product during installation or operation. Failure to follow information within this document will render all warranties given by Sleipner Motor as VOID.

Warnings and situations where extra caution is required are outlined. Take extra consideration when warnings are outlined within the documentation.



WARNING

Indicate a potentially hazardous situation that, if not avoided, could result in death or severe injury.



CAUTION

Indicates a potentially hazardous situation that could result in minor or moderate injury or critical damage to vessel integrity if not avoided.



Sleipner Motor AS
P.O. Box 519, Arne Svendsensgt. 6-8
N-1612 Fredrikstad, Norway

MC_0020

General:

- The installer must read this document to ensure necessary familiarity with the product before installation.
- Directions outlined in this document cannot be guaranteed to comply with all international and national regulations, including but not limited to health and safety procedures. It is the installer's responsibility to adhere to all applicable international and national regulations when installing Sleipner products.
- This document contains general installation guidelines intended to support experienced installers. Contact professional installers familiar with the vessel and applicable regulations if assistance is required.
- If local regulation requires any electrical work to be performed by a licensed professional, seek a licensed professional.
- To accommodate for future service and inspection requirements, ensure appropriate access to Sleipner products during the installation planning phase.

For Sleipner thruster systems:

MC_0425

- Do not install the thruster system in any position that requires modifying the stiffener/ stringer/ supports, which may jeopardize the hull integrity. Consult with the boat builder to see if this can be done safely if absolutely necessary.
- Never run the thruster out of water without load. Without load or resistance, the thruster propeller RPM will reach extremely high speed, damaging the system.
- The thruster motor must be handled with care. Do not rest the thruster on its drive shaft, as its weight can damage it.

For on-board electric motor driven systems:

MC_0031

- Ensure motors installed in small compartments are dry and well-ventilated to allow the electric motor to cool.
- The electric motor, components, and cables must be mounted to remain dry.
- The electric motor will reach over 100°C before activating the temperature switch. Any loose items near the thruster motor are a potential fire hazard and can cause short-circuiting.
- The thruster power supply circuit must include the recommended sized fuse and a battery isolation switch.

For DC electric motors:

MC_0426

- The electric motor will generate some carbon dust. Storage compartments must be separated from the thruster to prevent nearby items becoming dusty/ dirty. **(NB: IP version motors generate dust but are enclosed.)**

For lithium batteries for proportional thruster systems:

MC_0502

If a lithium battery system is installed to supply proportional thrusters such as SEP and E-series thrusters, ensure the battery is designed to output a continuous supply of the required thruster current. An under-rated battery management system can suddenly disconnect the load which may lead to dangerous situations. Ensure that you operate with high-quality batteries intended for maritime use.

- All Sleipner proportional thrusters will work well with Lithium batteries, as the included PPC unit will control the output voltage to safe levels for the thruster. **(NB: Ensure you have the latest embedded software installed. The firmware version of the Proportional Power Controller (PPC) must be of version 1.033 or later if the PPC is connected to a lithium battery).**
- All Sleipner eVision / E-series thrusters have built-in functionality to limit the maximum voltage delivered to the thruster.

(NB: Operating the thruster outside specified ratings will void the warranty).

For Sleipner S-Link™ systems:

MC_0105

When installing an S-Link™ system, connect ONLY original Sleipner S-Link™ products or other authorized control equipment directly to the S-Link™ bus. When connecting non-authorized third-party equipment, it must always be connected through a Sleipner-supplied interface product.

Any attempt to directly control or connect to the S-Link™ control system without a designated and approved interface from Sleipner will void all warranties and responsibilities of the connected Sleipner products. If you interface the S-Link™ bus by agreement with Sleipner through a designated Sleipner-supplied interface, you are still required to install at least one original Sleipner control panel to enable efficient troubleshooting if necessary.

Sleipner develops IP (Ignition Protected) products suitable for marine engine compartments and fuel tank spaces. Combination products sold as complete systems may combine IP and non-IP items.

CAUTION

- ! The installer is responsible for identifying ignition-protected and non-ignition-protected products when considering installation locations. Unique installation considerations must be taken to maintain ignition-protected specification in areas requiring ignition-protection. For installations requiring ignition-protected equipment, ensure only ignition-protected products, fuse, and main switch are used. Always follow your national regulations for ignition-protected certification.

For Ignition Protected systems:

MC_0007

CAUTION

- ! NEVER Disassemble any part of the Ignition Protected assembly. Tampering with the Ignition Protected assembly will cause it to lose this safety feature. If there is a problem with your Ignition Protected motor, please contact your dealer.

Measurement code	Measurement description	SE IP 30 12v		SE IP 40 24v	
		mm	inch	mm	inch
ID	Internal tunnel diameter	125	4,92	125	4,92
H	Motor Height	291	11,46	288	11,34
W	Width	234	9,21	234	9,21
L	Length	238	9,37	238	9,37
WD	Water Depth	125	4,92	125	4,92
TL	Minimum tunnel length	111	4,37	111	4,37
TL (recommended)	Recommended tunnel length	136	5,35	136	5,35
T (min)	Minimum tunnel wall thickness	4	0,16	4	0,16
T (max)	Maximum tunnel wall thickness	6	0,24	6	0,24

*Valid for SE IP & SEP IP

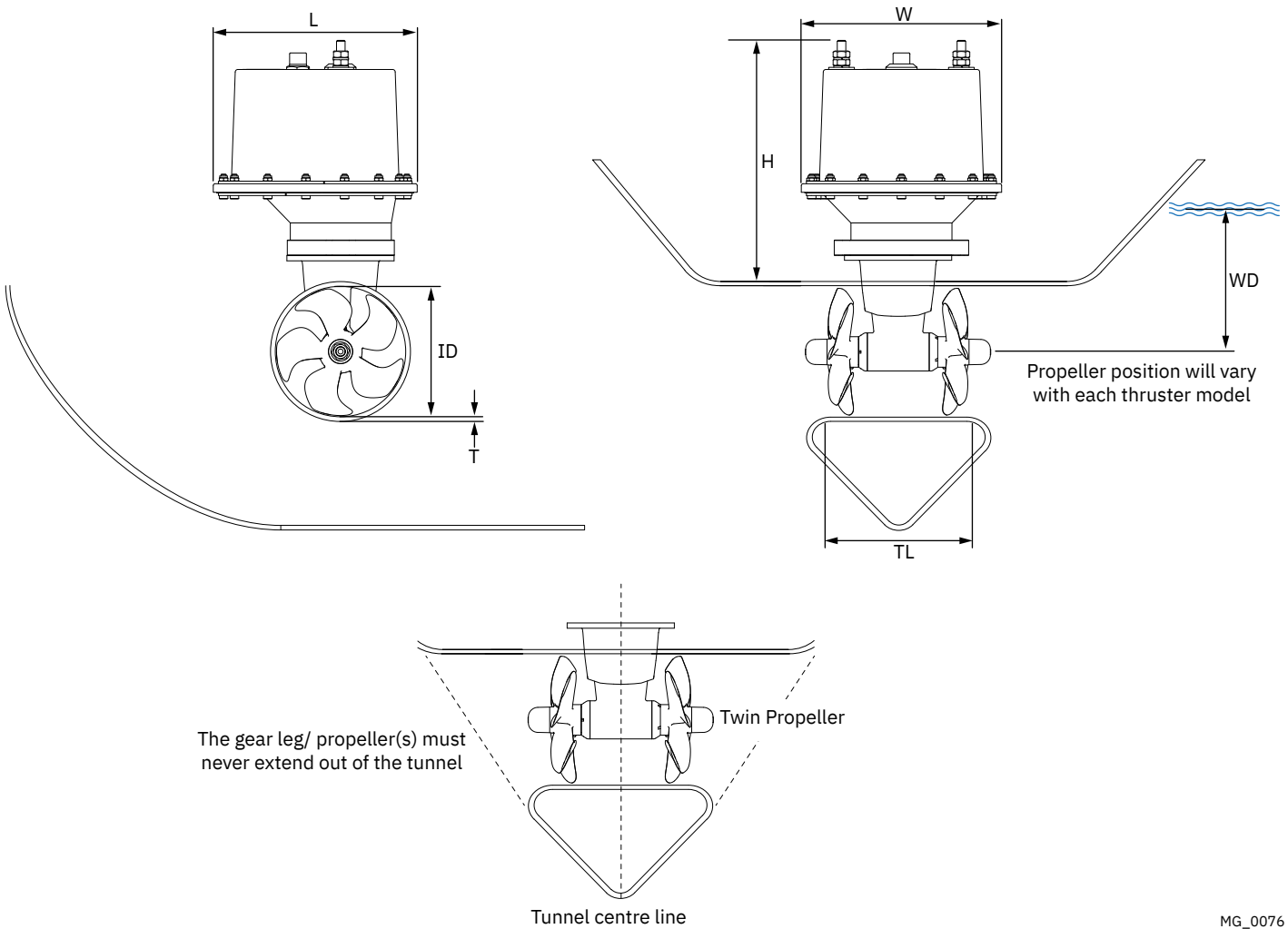

MG_0076

This product has clearance considerations extending the base product footprint. Follow the clearance requirements when planning your installation.

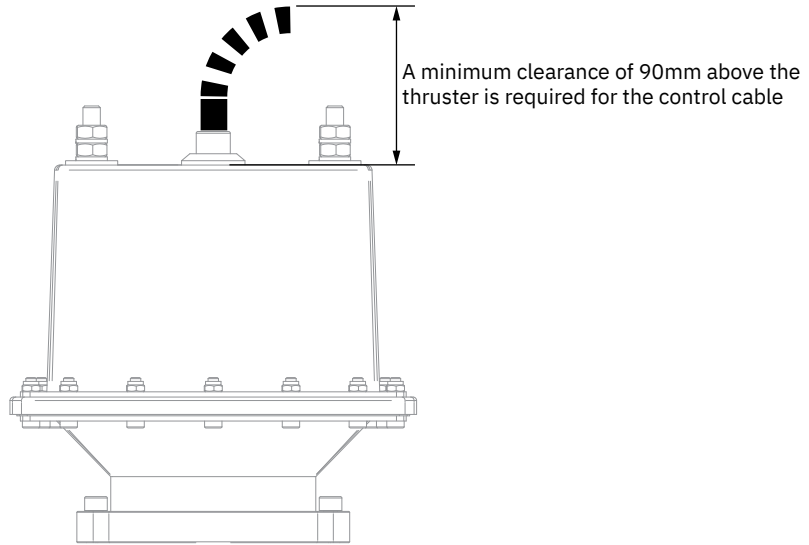

MG_0592

Product Specifications

MC_0504

Product	Maximum Supply Voltage *	Thrust at 12V	Thrust at 10.5V(12v)	Power Output (kw / Hp)	Weight (kg / lbs)	Maximum Operation Time
SEP20 12V	15.5V	25 kg / 55 lbs	20 kg / 44 lbs	1.5kw / 2hp	9.5kg / 21lbs	S2 motor at 2 - 3 min. Duty cycle at 20°C (Ambient temperature)
SEP25 12V	15.5V	30 kg / 66 lbs	25 kg / 55 lbs	1.5kw / 2hp	9.5kg / 21lbs	
SEP30 12V	15.5V	40 kg / 88 lbs	30 kg / 66 lbs	1.5kw / 2hp	9.5kg / 21lbs	
SEP40 12V	15.5V	48 kg / 105 lbs	40 kg / 88 lbs	2.2kw / 3hp	10kg / 22lbs	

* SEP and SEP-IP are measured at PPC supply terminals for proportional thrusters

1. Aim to install the thruster as far forward as possible

Due to the leverage effect around the boats' pivot point. The distance difference from the boat pivots' point to the thruster will determine the amount of real rotation power for the boat.

2. Aim to install the thruster as deep as possible under the waterline

Deeper installations prevent air from being sucked into the tunnel from the surface, resulting in reduced thrust performance and increase noise levels during operation. Deeper installations increase water pressure for maximum efficiency from the thruster.

The centre of the tunnel should be as a general rule minimum of 1 x the tunnel diameter below the waterline. **(NB: Refer to product measurements to define your products recommended depth below the waterline.)** The installer must make evaluations based on thruster performance, boat type and operating conditions. As a general recommendation, the position of the tunnel should not be a minimum of 1/4 of the diameter of the tunnel from the boat keel. **(NB: This can be overlooked depending on the installation methods defined in this manual.)**

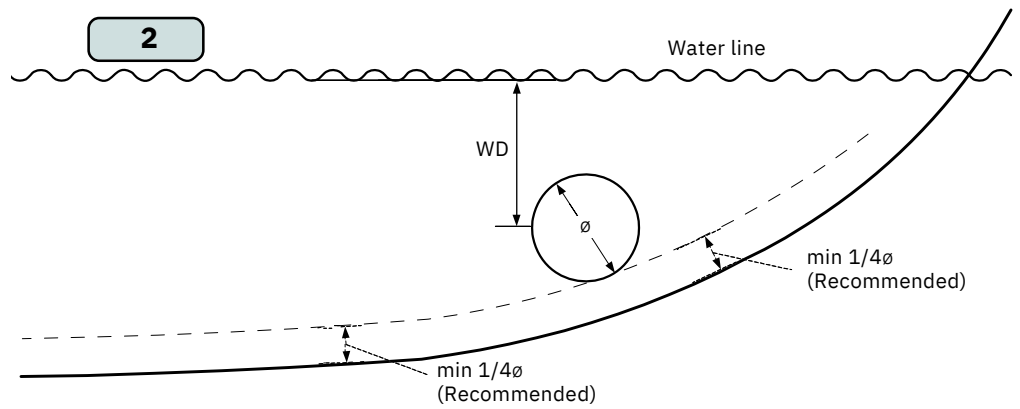
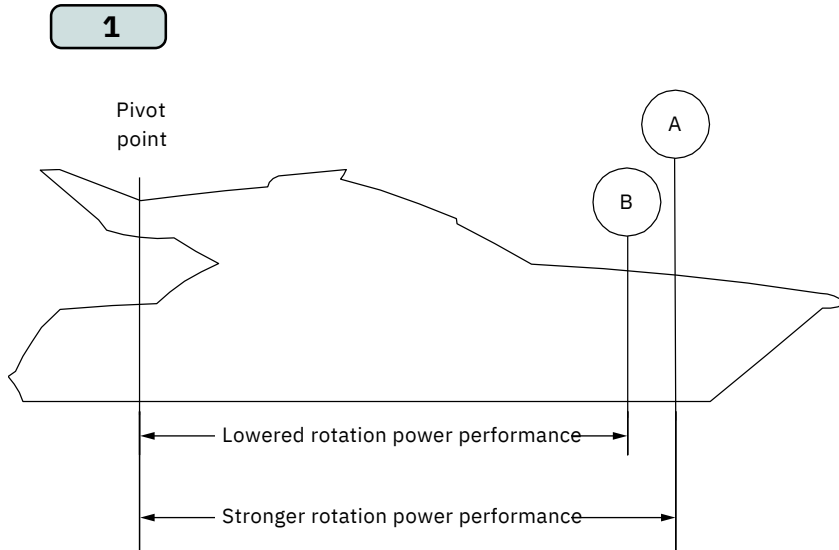

Optimal tunnel length

Achieving the correct tunnel length depends on many factors from the hull type, operation and environmental conditions.

Tunnels should avoid being longer than 4 x the tunnel diameter as this will reduce thruster performance. **(NB: Installing long length tunnels can flex/bend over time and may require additional support. Consult with a naval architect.)**

1. Do not allow the variable length of the tunnel walls to vary in length excessively.
EG. The top tunnel wall is x 4 longer than the bottom wall.
2. If the tunnel is too long, the friction inside will reduce the water speed and thereby the thrust.
3. If the tunnel is too short (typically only in the bottom section of the tunnel) cavitation problems can occur as water flow will not be able to "straighten" itself before reaching the propeller. This cavitation will reduce performance and increase noise during operation.

Thruster within the tunnel

It is important the propellers and the lower unit/ gear leg must be entirely inside the thruster tunnel. Propellers that protrude from the tunnel will not perform as intended.

4. Standard Use

Tunnel length must be long enough to ensure the propellers are not extruding the tunnel. **(NB: Refer to product measurements to define your products recommended tunnel length.)**

5. Flat Bottom Hull

Tunnel lengths must be longer than the standard measurement outlined within the manual to ensure a circular vacuum is not created between the thruster and the bottom of the boat.

6. High-Speed Boats

Tunnel lengths must be increased to protect the propeller from damage when crashing against the water surface during high-speed cruising. **(NB: This can include the length of a spoiler)**

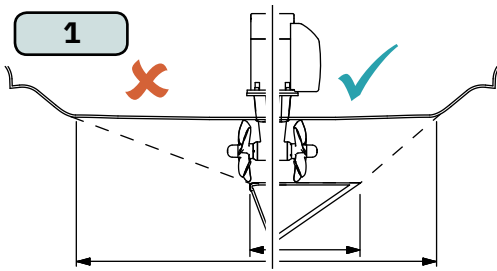

Do not allow the variable length of the tunnel walls to vary in length excessively.
EG. the top tunnel wall is x 4 longer than the bottom wall.

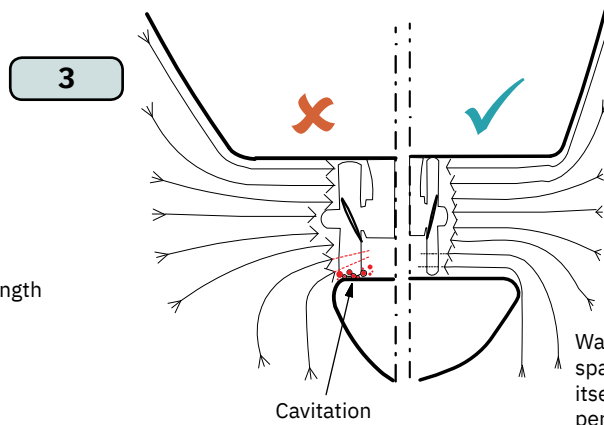

Water flow must have space to "straighten" itself for best performance.

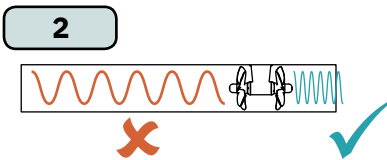

4 STANDARD USE

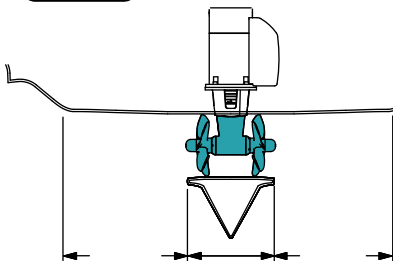

The gear leg/ propeller(s) must never extend out of the tunnel

5 FLAT BOTTOM HULL

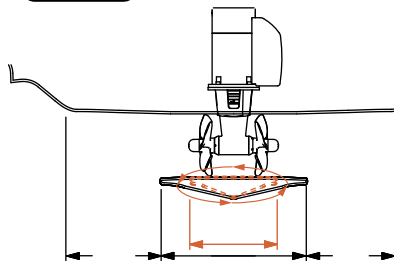

Increase tunnel length to prevent a circular water vacuum cavity between the propeller and the hull of the boat.

6 HIGH-SPEED OPERATION

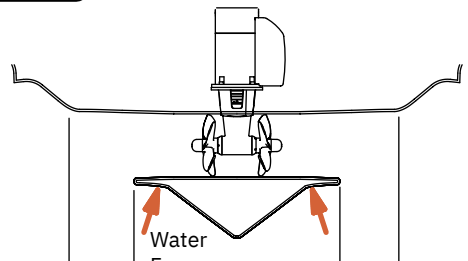

Increase tunnel length to protect the propeller from water forces when high-speed cruising.

MG_0048

Some sail boats have a flat bottom and shallow draft in the bow section. This can make installing the thruster as far forward from the boats main pivot point difficult.

However, it is possible to install a tunnel thruster in most sail boats, even when the hull does not directly support the fitting of a tunnel.

Instead fit the tunnel halfway into the underneath section of the existing hull. Strengthen it with a deflector/ spoiler directing the water flow around the tunnel. This will allow installation of the thruster in the proper position on the boat, maintaining the reliability and space advantages of the tunnel thruster.

This installation is being used by some of the world's largest sail boat builders and has proven to give little to no speed loss during normal cruising. This can also be an installation method for flat bottomed barges to avoid extremely long tunnels and large oval tunnel openings in the hull.

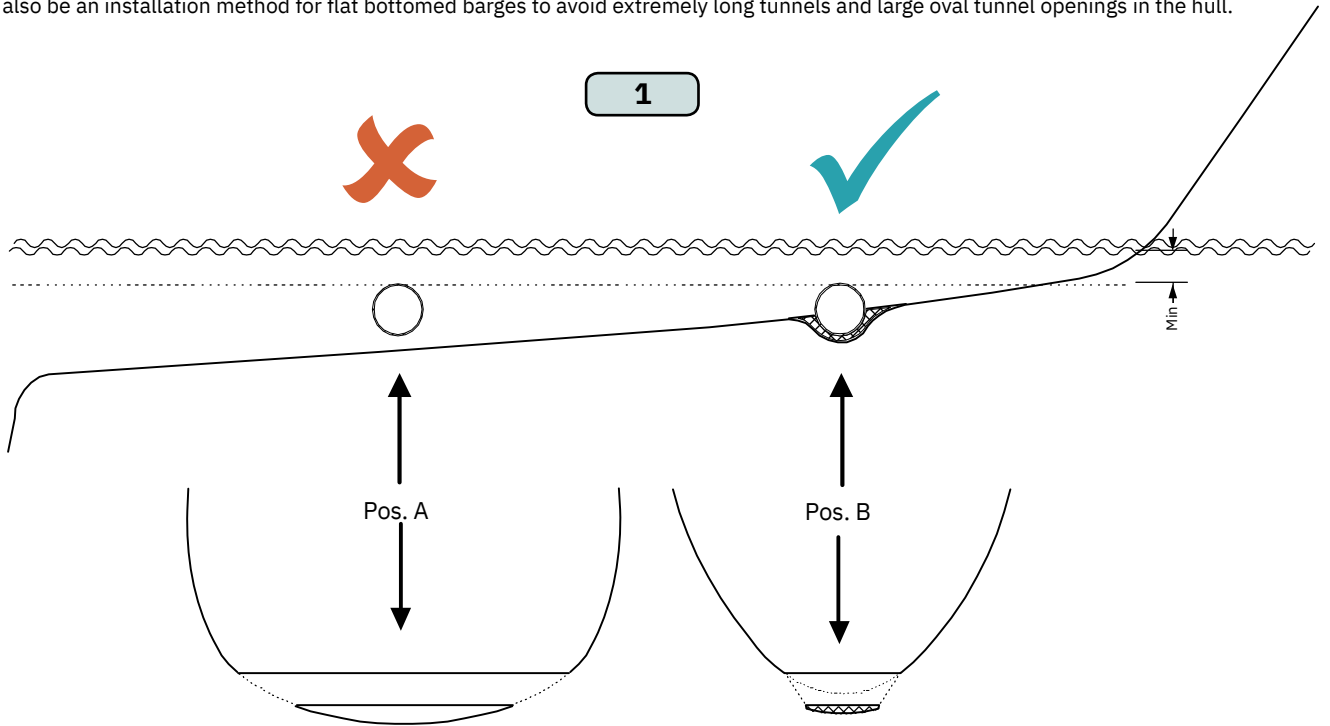

1. A possible problem in sail boats or fast powerboats is that a non-rounded surface can generate drag from the back face of the tunnel, as it creates a "flat" area facing the flow of water.

This problem can be solved in two different ways, depending on what is possible or easier to perform.

2. The best solution which generally reduces the most drag is to make a recess in the hull at the back of the tunnel. As the back face is removed water can flow freely past the tunnel entry. The depth and shape of this recess will depend on the boat and the angle facing up/ down aft of the tunnel insert. Normally it is angled slightly down because of the water flow on this area.
3. Making a deflector/ spoiler in front and underneath the tunnel can also reduce damage to the thruster and drag. The deflector/ spoiler will push the water flow out from the hull so water can pass by the back face of the tunnel. The shape and size of this deflector/ spoiler will depend on the hull shape. The easiest way of making the deflector/ spoiler is to retain a part of the lower forward area of the tunnel while installing the tube. Use this area as support to mould a soft curve/spoiler shape from the hull.
4. The thruster propeller can spin (passively) producing noise while sailing or cruising as water is forced through the tunnel. Water-flow directed through the tunnel at high speeds, during turning or as the boat bumps waves while underway can also damage the thruster.

(NB: As a rule, you should not see the back face of the tunnel when standing directly in front of the boat looking aft.)

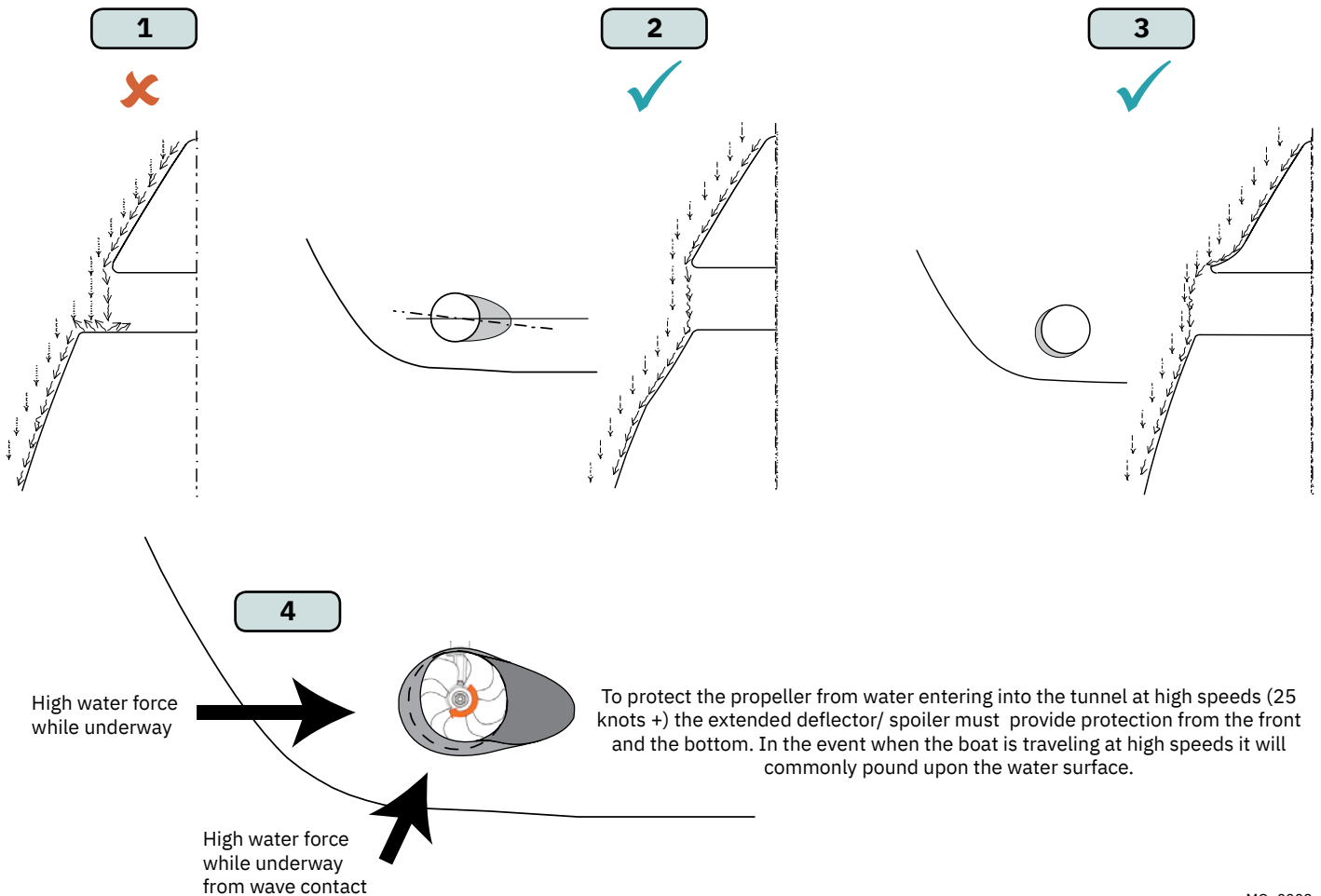

Rounded tunnel ends will maximise thrust and minimise noise and cavitation.

For best performance round the tunnel connection to the hull-side as much as possible. The minimum rounding has a radius of 10% of the diameter of the tunnel.

Significant advantages of a rounded tunnel over a sharp tunnel to hull connections are:

1. A rounded tunnel end will prevent the creation of turbulence/ cavitation created from a sharp tunnel end when water passes by the tunnel.
 - The turbulence/ cavitation will block the outer area of the tunnel and thereby reduces the effective tunnel diameter and thrust.
 - Turbulence/ cavitation on the propeller will lessen the thrusters performance and create excess noise.
2. For steel/ aluminium hulls angled tunnel ends also offer similar performance as a rounded connection.
3. A rounded tunnel end makes the thruster draw water from along the hull-side, creating a vacuum that will suck the boat sideways and thereby give additional thrust.
 - With a sharp tunnel end, the thruster will be unable to take water from along the hull-side, and you will not gain the desired vacuum and additional thrust. This “free” extra thrust in optimal installations be 30 - 40% of the total thrust.

(NB: A Slooper thruster propeller does not produce cavitation at working speed. Therefore, any cavitation and cavitation noise in the tunnel will be caused during improper tunnel installation.)

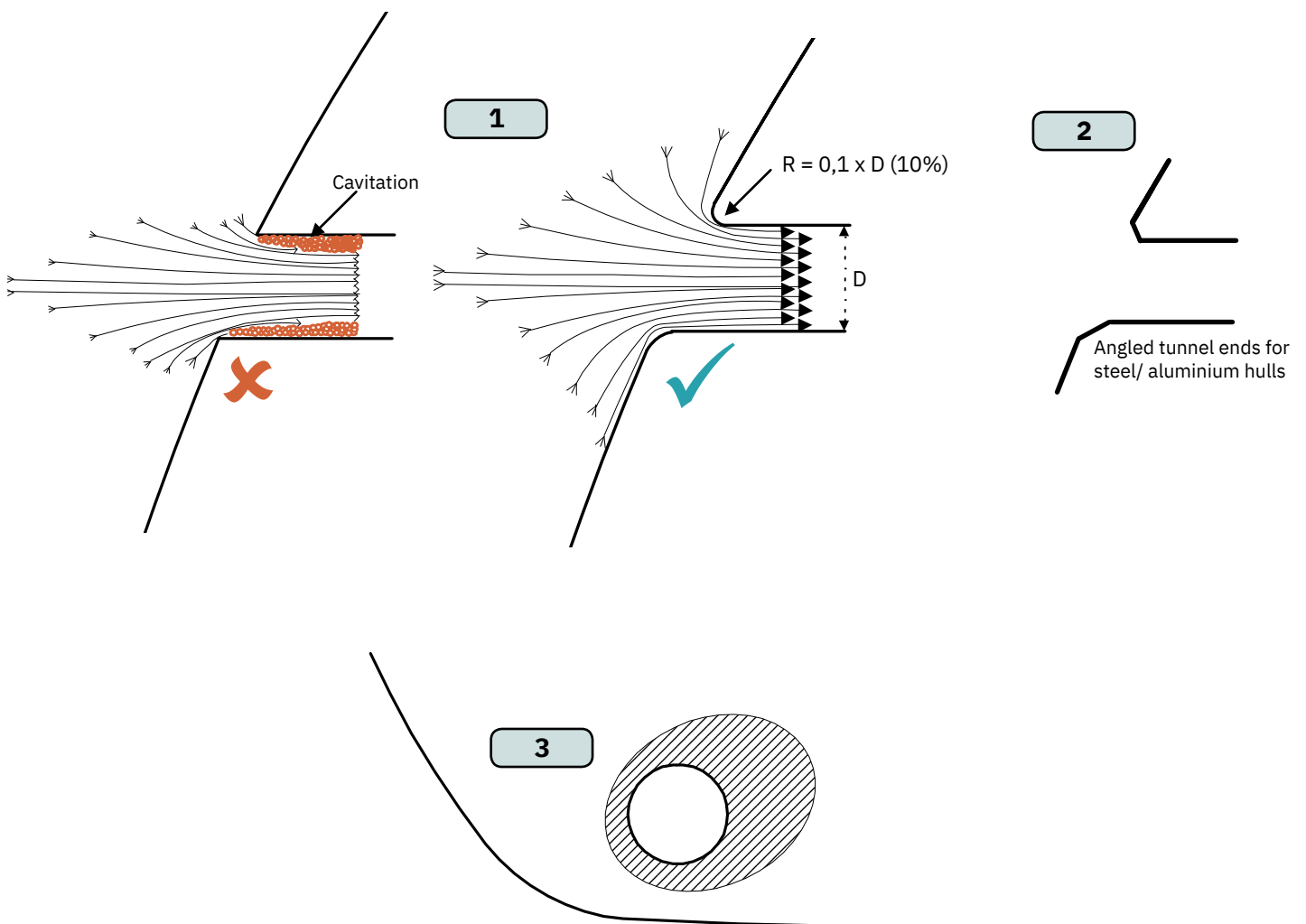

The following are only general instructions and do not explain in any way the details of fibreglass work. Problems caused by faulty installation of the tunnel, are the installers full responsibility. Seek a professional boat builder when modifying the hull.

1. Find the position in the boat considering the information earlier in this manual and the applicable measurements for the thruster model you are installing. Mark the centre of the tunnel on both sides of the hull. Drill a hole horizontally at these marks.
2. Mark the circle for the tunnel opening (outside diameter of the tunnel) and cut the hole.
3. Grind off the gel coat to the "real fibreglass" area 12cm around the hole on both inside and outside the hull to cast the tunnel to the hull (**Fig. 3**).
4. Insert the tunnel and mark its shape to fit the hull. (**NB: if you are installing with a deflector/ spoiler, leave a part of the tunnel in the front and underside of the tunnel that will cover the back face.**)
5. Cut the tunnel ends to the desired shape and lightly sand its surface. Clean the area with acetone or similar where you are going to apply fibreglass. (**NB: Do not cast or add fibreglass to the area were the thruster will be placed.**)
6. Cast the tunnel to the inside of the hull, use at least eight layers of 300g fibreglass and resin, preferably alternating mat and rowing types of fibreglass. To round the tunnel ends to a 10% radius make further layers inside to preserve the desired hull thickness.

(NB: Ensure gaps between the tunnel and the hull are completely filled with resin/ fibreglass. In areas where you can not access to make layers of resin/ fibreglass, a resin/ fibreglass mixture must be used in that area.)

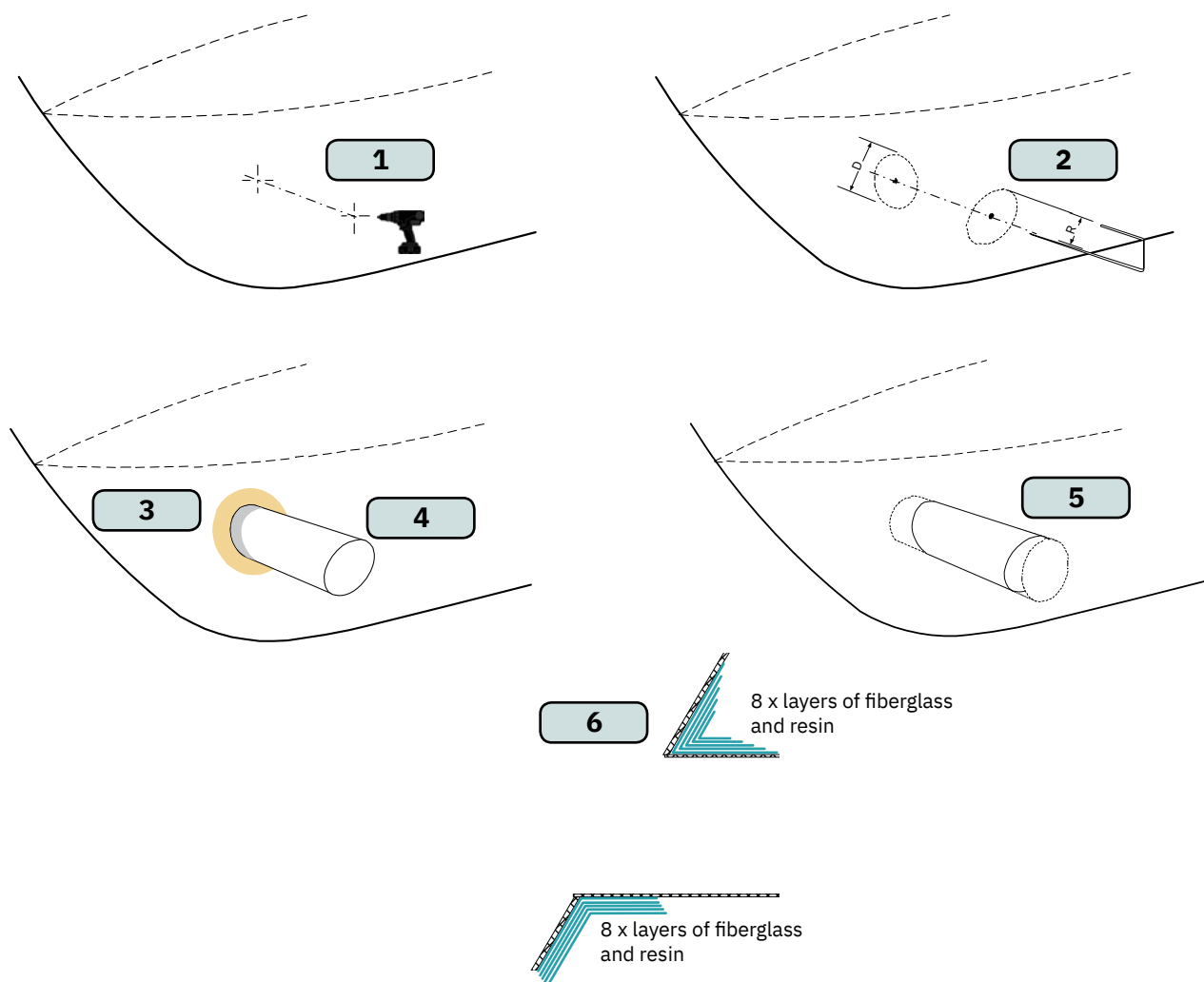

With tunnel installed and cast.

1. Round the edges with a radius of 10% of the tunnel diameter.
2. For steel/ aluminium hulls make a slope with a length of 10-15% of the tunnel diameter. **(NB: If this is not possible, round the tunnel end as much as possible.)**
3. Additionally cast two layers on the outside of the tunnel/ hull in a 10cm area
4. Follow the same method if making the deflector/ spoiler.

You must apply gel coat to areas you have grounded/ moulded to make waterproof. These areas allow water access to the hull which is typically not waterproof without these applications outside. **(NB: All original Sleipner tunnels are fully waterproof when delivered except in the areas where you have cut and bonded it to the hull.)**

Avoid all casting where the motor-bracket is to be placed, as this will cause misfit and possible failure to the gear house.

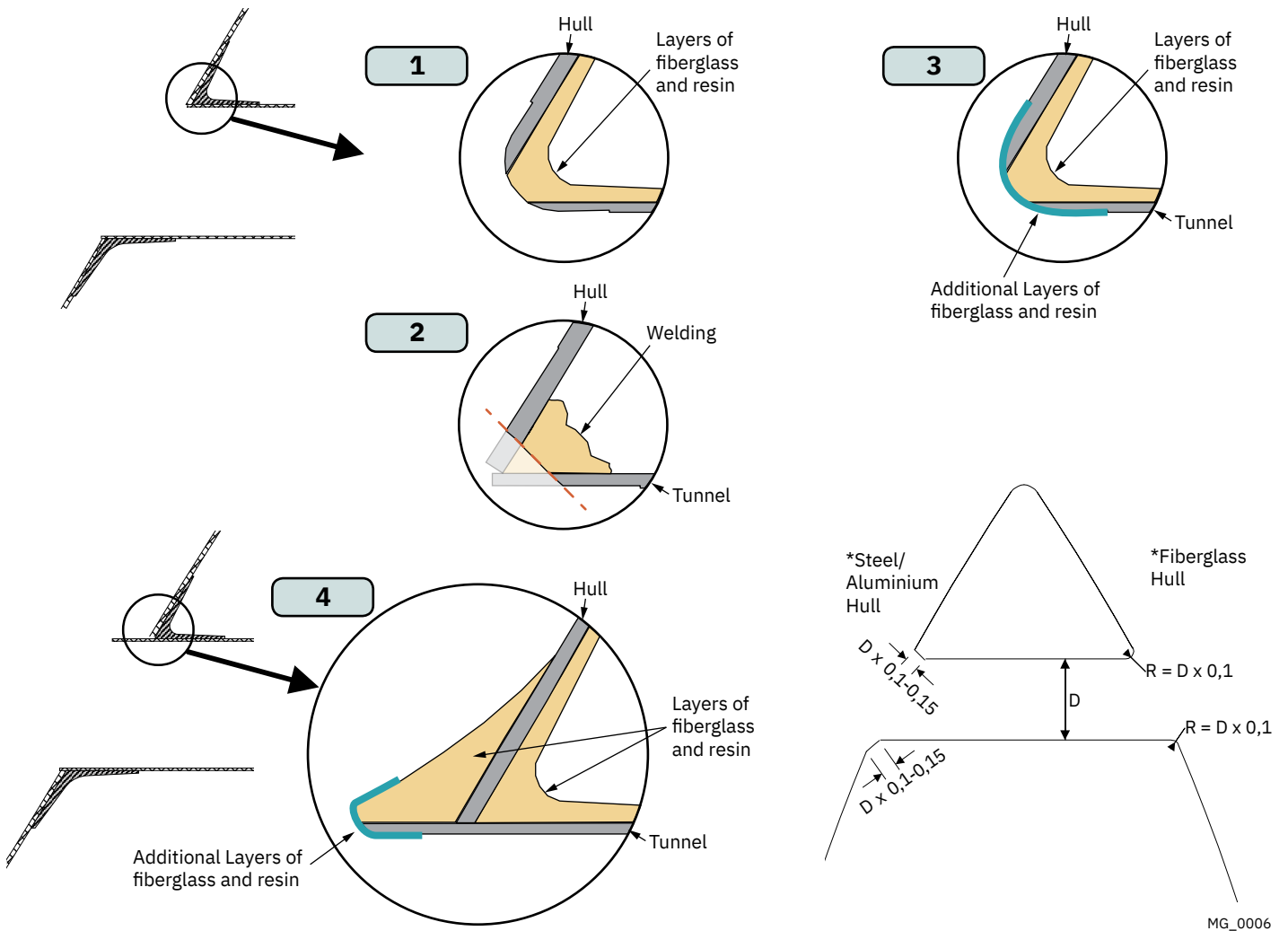

For **Stern Thruster** installation please refer to the supplied manual in your Sleipner product delivery



For supporting stern tunnel installation documentation, we advise you to visit our website www.sleipnergroun.com and find your Sleipner stern tunnel model.

Please refer to the graphic for special considerations relating to your model

1. Mark the tunnel centreline and the boat's centreline. **(NB: Install the gear leg and propeller as shown for the thrust direction to correspond with the control panel.)**
2. Use the gasket or template (recommended) to mark the hole centres and double-check the measurements. One hole **MUST** be placed using the boat centreline as shown above. **(NB: All holes must be in-line with the tunnels' centreline for correct installation, clearance between the propeller and the tunnel is minimal.)**
3. Drill the main centre hole followed by the two screw-holes.
4. Smooth the surface of the tunnel. A rough surface will cause possible failure/ movement of the gear leg. The motor bracket must rest steadily on the tunnel.

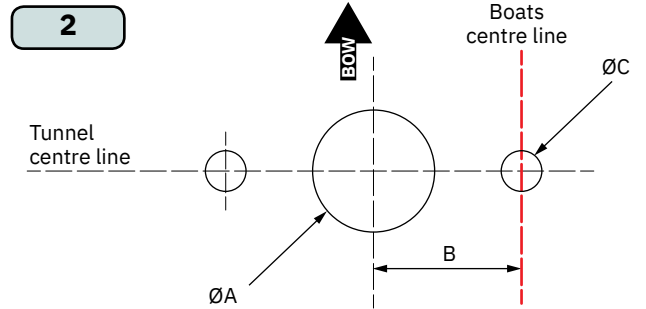
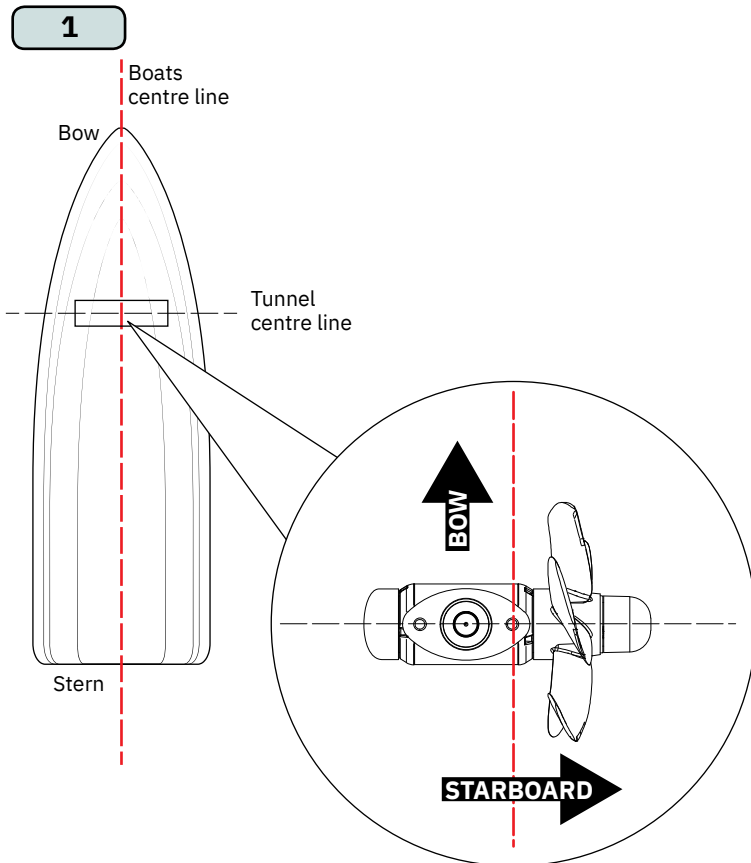

Models	Measurements					
	ØA		B		ØC	
	mm	inch	mm	inch	mm	inch
SE20/110S SE25/110S	28	1,1	20	0,8	7	0,3
SE/SEP/SE IP/SEP IP 30/125S2 SE/SEP/SE IP/SEP IP 40/125S2	28	1,1	21	0,8	8,5	0,3
SE/SEP/SE IP/SEP IP 30/140S SE/SEP/SE IP/SEP IP 40/140S SE/SEP/SE IP/SEP IP 50/140S SE/SEP/SE IP/SEP IP 60/185S2	29	1,1	23	0,9	8,5	0,3

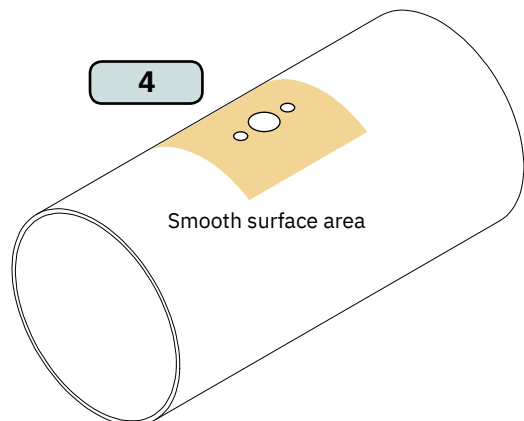
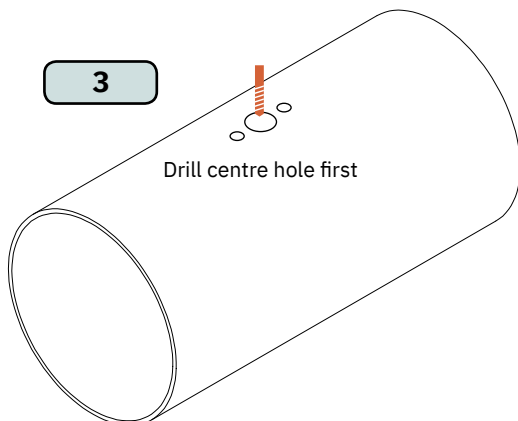

Please refer to the graphic for special considerations relating to your model

5. Place the gear leg (without the propeller) with the gasket on inside the tunnel.
6. Place the propeller on the gear leg (**NB: Do not secure the propeller with securing parts**) to ensure it is centred and rotates freely with the same clearance from each blade to the tunnel wall.
7. Place top motor bracket and bolt plate to measure the drive shaft has come through the motor bracket at the correct height. Remove the gear leg and propeller for final installation.

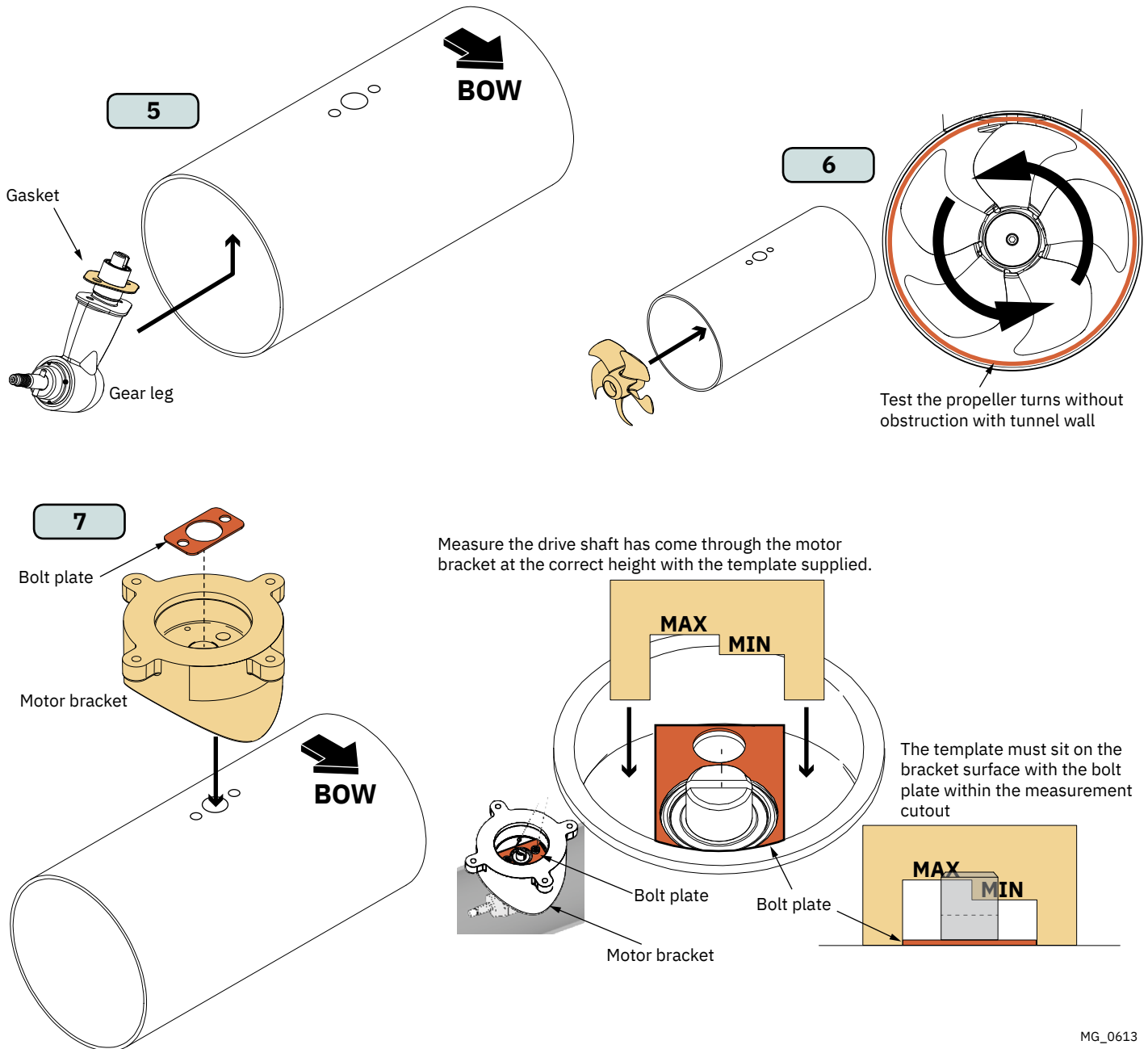

MG_0613

Please refer to the graphic for special considerations relating to your model

8. Apply appropriate sealant to both sides of the gasket and place on the gear leg. Place the gear leg in the tunnel (without the propeller). Use appropriate sealant to ensure that no leakages occur. **(NB: See your sealant data sheet for the correct application process.)**
9. Install the top motor bracket and gear leg gently together.
10. Fasten the gear leg and the motor bracket with the bolts provided. Tighten to torque as shown.

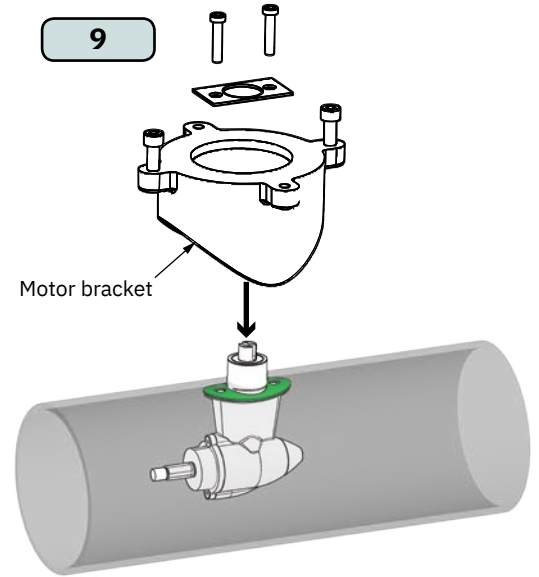
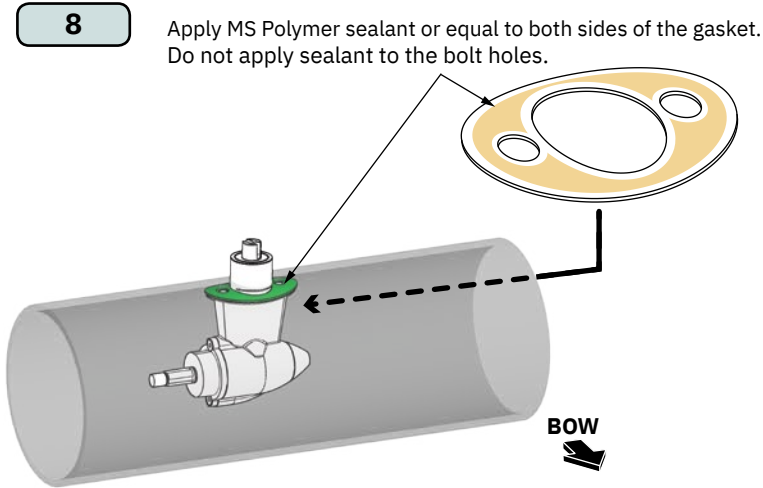

10

Tunnel Diameter	/110mm		/125mm	
Fasten	Nm	lb/ft	mm	inch
	12	8,85	18	13,3

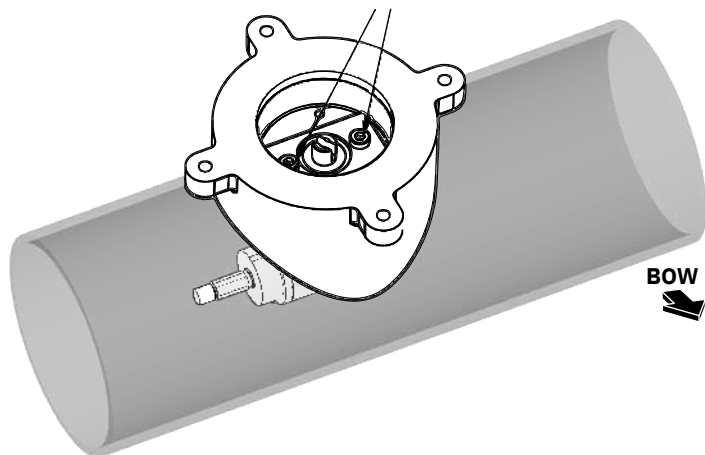

MG_0614

Propeller Installation

MC_0017

Please refer to the graphic for special considerations relating to your model

1. Insert the propeller onto the shaft spline. Rotate the propeller until the shaft spline aligns with the internal spline in the propeller.
2. Insert the washer to the end of the shaft spline. Fasten with the propeller lock-nut.
3. Apply anti-fouling to the gear leg and propeller. Do not apply anti-fouling to any rubber elements of the gear leg or anodes.

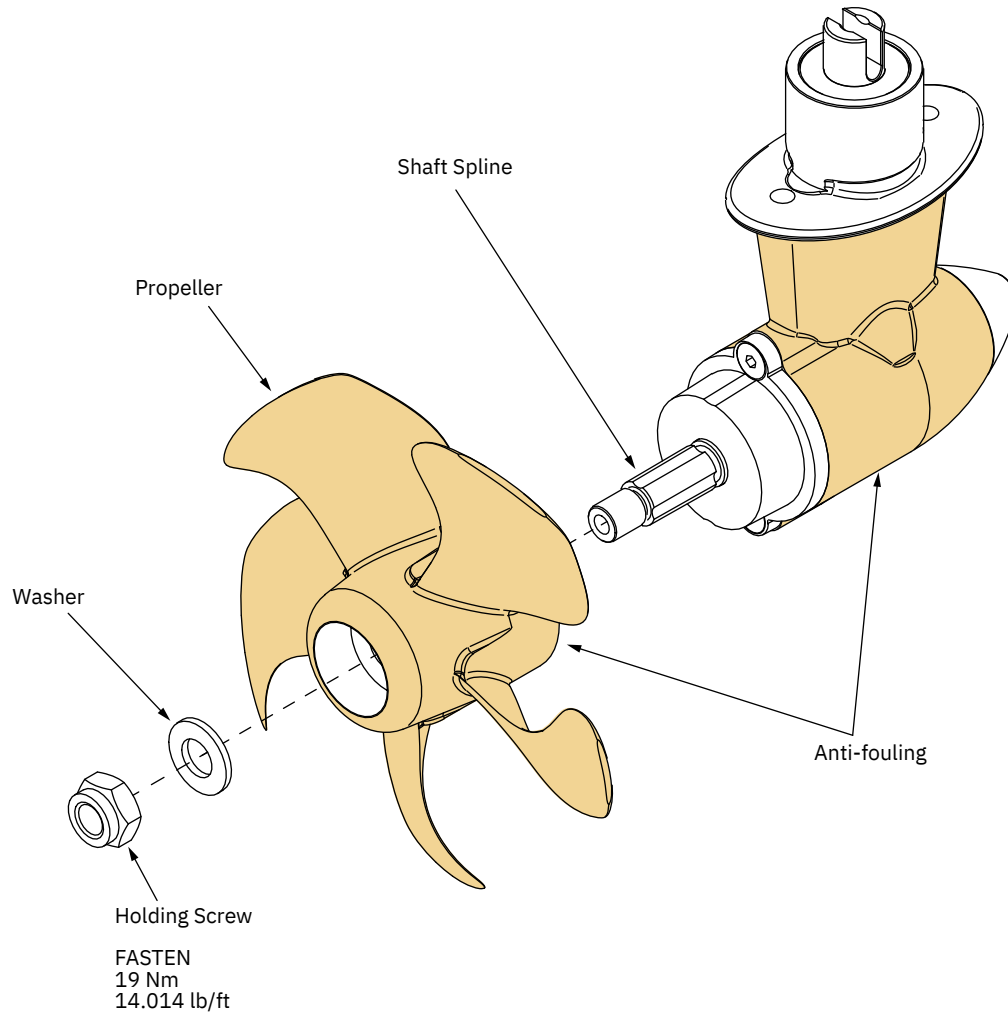

MG_0050

Please refer to the graphic for special considerations relating to your model

1. Insert the drive pin to the motor drive shaft. Insert the coupling to align with the drive pin in the motor shaft.
2. Install the motor onto the motor bracket ensuring the couplings are engaged together correctly (top and bottom). **(NB: The motor can be placed in all directions on the motor bracket. However, ensure the cable terminals are accessible for electrical installation later.)**
3. If you are installing the motor at an angle of more than 30 degrees off vertical, the motor will require separate/ additional support. **(NB: Do not position supports on the motors top cap.)**
4. Fasten the bolts holding the motor to the motor bracket with the below torque.
5. Check the drive shafts are engaged by rotating the propeller. **(NB: Rotating the propellers can be hard due to the gear reduction and the motor, however the propeller must be able to rotate via hand power.)**

(NB: The thruster motor assembly must be protected using suitable covering to avoid dust/debris ingress from fabrication/maintenance/shipbuilding operations. On completion of operations, the cover must be removed before operating the thruster.)

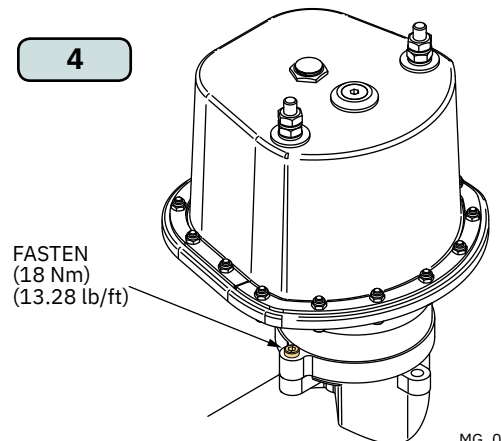
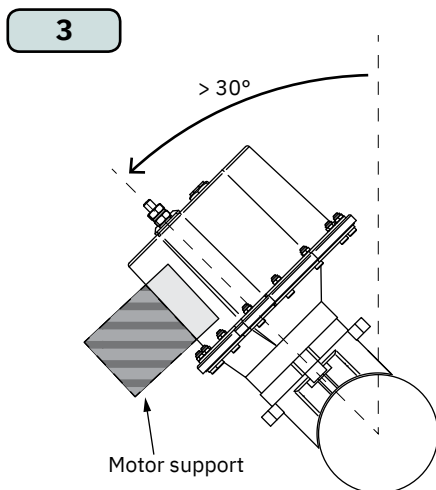
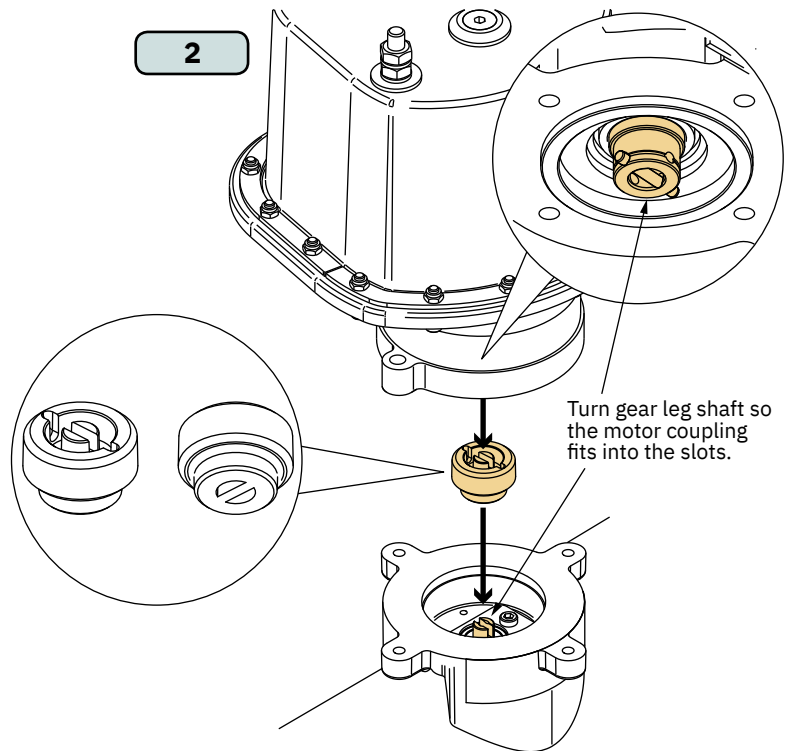
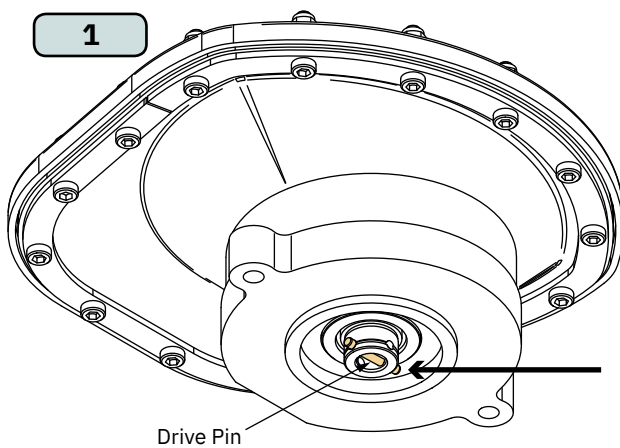

MG_0066

1. Plan the location of electrical components before starting with the electrical installation. Main electrical components will typically consist of battery, fuse, main switch, Proportional Power Controller (PPC) and thruster motor, see Wiring Diagram chapter for an overview.

Sleipner offers both manual main switches and Automatic Main Switches (AMS). Sleipner AMS is controlled by the control panel in addition to the option of manual operation. Turning on the control panel also turn on the automatic main switch. When the control panel is turned off the automatic main switch is turned off. This ensures that the control electronics and motor are only energized when the control panel is turned on. Sleipner offers AMS supporting either S-Link or ON/OFF control panels. Note that the AMS requires a separate power supply which should be protected by a dedicated fuse. Ensure to select an AMS with a voltage rating according to the chosen motor- and battery voltage.

Electrical products installed in gasoline engine spaces or other areas potentially exposed for explosive gases must be Ignition Protected. Products installed in such locations should conform to the ISO 8846, SAE J1171 or UL 1500 standard.

2. Estimate the total length of the power cables to determine the recommended cross-section. The total power cable length is defined as the distance from the positive battery terminal, via fuse, main switch, PPC, and thruster motor, and all the way back to the negative battery terminal.
3. Find the recommended power cable cross-section for the installation by using the estimated total power cable length and the table shown in the chapter Electrical Reference Guide.
4. Select the recommended fuse size by using the table shown in the chapter Electrical Reference Guide.
5. Use an appropriate dimensioned battery with Cold Cranking Amps (CCA) according to recommendations given in the Electrical Reference Guide chapter. Battery voltage must be compliant with the voltage rating of the thruster motor and control circuitry. The capacity and rated discharge current of the battery should be according to the rated nominal current drawn and the typical duty cycle for thruster operation. The nominal current drawn is listed in the Electrical Reference Guide chapter.

The actual voltage at the motor while running the thruster determines the motor RPM and thrust. Using a smaller cross-section than recommended or a low-capacity battery could reduce performance.

Installing a battery close to the thruster reduces the length of the power cables and potentially increases the performance, due to lower voltage drop in the power cables. For installations on large vessels with bow and stern thrusters or catamarans a dedicated battery for each thruster should be considered.

6. Install and connect the electrical components according to the applicable Wiring Diagram chapter.

For safety reasons it is always recommended to install a fuse and a main switch on the power cables and as close as possible to the positive battery terminal. The main switch must be installed such that it is easily accessible so that the thruster can be electrically disconnected to a safe state when not on-board or in the case of an emergency.

For dual thruster systems using only one battery bank a dedicated fuse and main switch should be installed for each thruster. These should be installed close to the battery bank.

Follow the instructions in the Motor Lug Connection chapter when fastening the power cables to the motor.

7. For detailed instructions on PPC installation consult the PPC Installation Guide included with the PPC.
8. Fuse and main switch should be installed according to the installation manual accompanying the products.
9. Install the control panel according to the instructions in the Installation Guide included with the control panel.
10. See the S-Link System Description chapter for detailed information on the installation of the S-Link Power cable and additional S-Link components.

CAUTION



After all electrical connections have been completed, turn off main switch and check the following with an ohmmeter:

1. There is no electrical connection between electro-motor flange and the positive terminal on the motor.
2. There is no electrical connection between electro-motor flange and the negative terminal on the motor.

If unsure contact skilled personnel.

Product Lug Connection Configuration

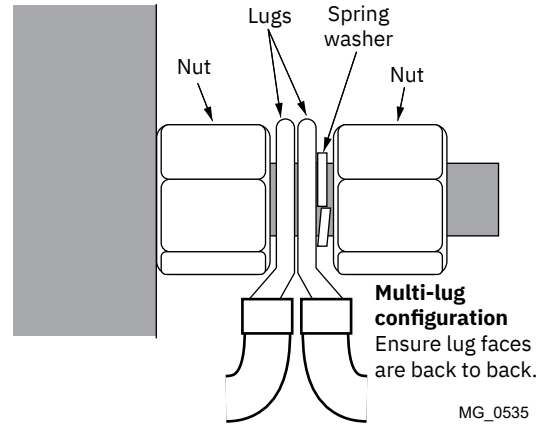
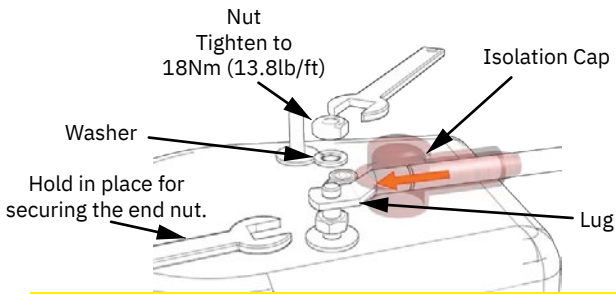

! **CAUTION**
Do not use washers between lugs, this causes overheating and fire. Spring washers must be placed in the outer position before tightening nut.

MG_0535

Electrical Reference Guide

MC_0615

Model Size	System Voltage	Nominal current	*Min. battery CCA	Rec. fuse	Cross Section Guide for Power Cables												
					Unit	<7m total + & -		7-14m total + & -		15-21m total + & -		22-28m total + & -		28-35m total + & -		36-45m total + & -	
						Min.	Rec.	Min.	Rec.	Min.	Rec.	Min.	Rec.	Min.	Rec.	Min.	Rec.
20/110S	12V	150 A	DIN: 200 SAE: 380 EN: 330	ANL 150	mm ²	25	35	35	50	50	70	70	95	95	95	120	2 x 70
					AWG	3	2	2	1/0	1/0	2/0	2/0	3/0	3/0	3/0	2 x 4/0	2 x 2/0
25/110S	12V	200 A	DIN: 200 SAE: 380 EN: 330	ANL 150	mm ²	25	35	50	50	70	70	95	95	120	120	2 x 70	2 x 70
					AWG	3	2	1/0	1/0	2/0	2/0	3/0	3/0	4/0	4/0	2 x 2/0	2 x 2/0
30/125S 30/140	12V	245 A	DIN: 200 SAE: 380 EN: 330	ANL 150	mm ²	35	50	50	70	70	95	95	120	120	2 x 70	2 x 70	2 x 95
					AWG	2	1/0	1/0	2/0	2/0	3/0	3/0	4/0	4/0	2 x 2/0	2 x 2/0	2 x 3/0
40/125S 40/140	12V	315 A	DIN: 300 SAE: 570 EN: 520	ANL 250	mm ²	35	50	70	95	95	120	120	2 x 70	2 x 95	2 x 95	2 x 120	2x 120
					AWG	2	1/0	2/0	3/0	3/0	4/0	4/0	2 x 2/0	2 x 3/0	2 x 3/0	2 x 4/0	2 x 4/0

Manual Main Switch Wiring Diagram 12V S-Link IP Thruster

The Top wiring setup is for a single bow OR stern thruster system

See S-Link System Description chapter for detailed information on installation of S-Link POWER Cable, END Terminator and additional S-Link components.

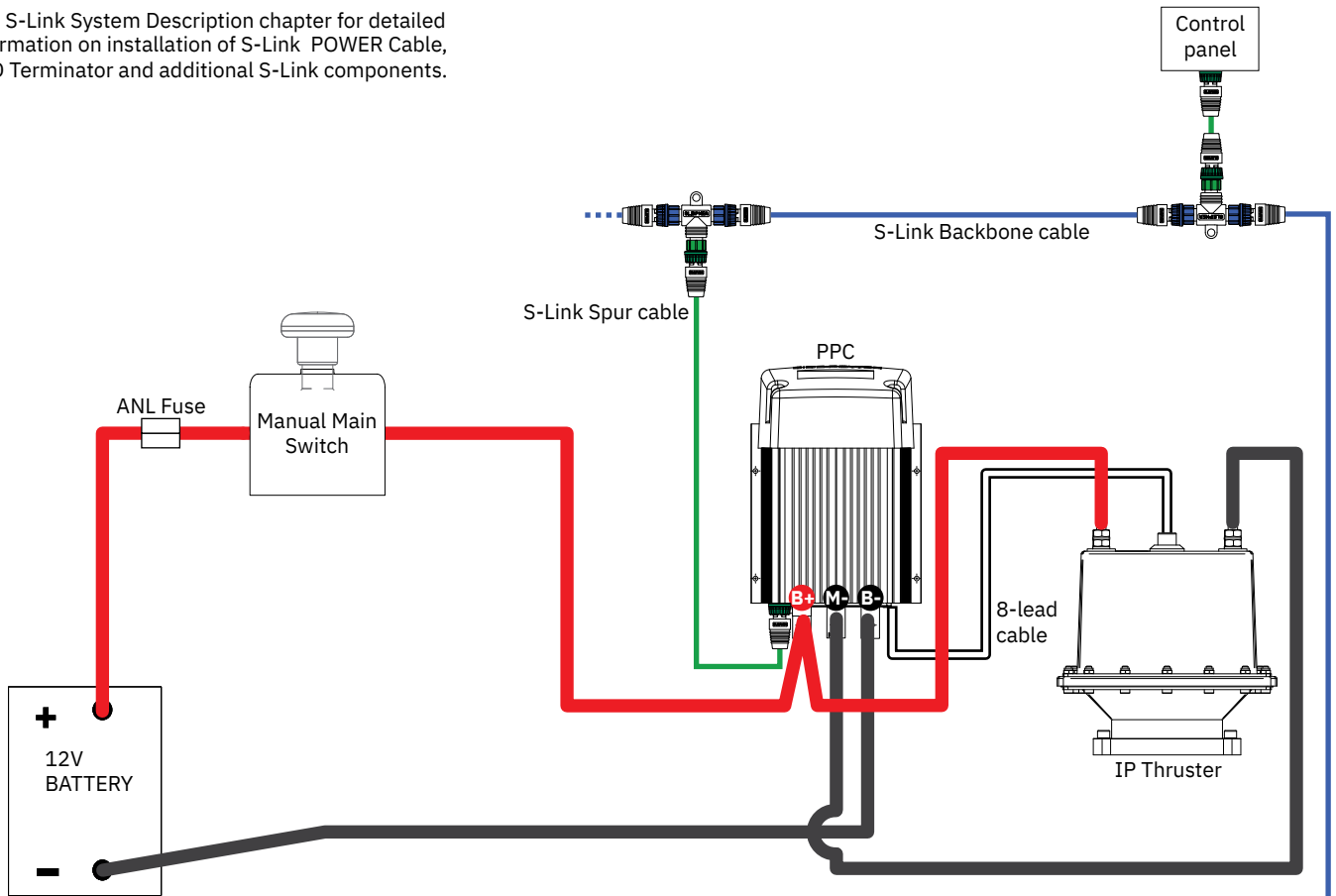

The top and bottom wiring setup is for a dual thruster system, For example bow and stern.

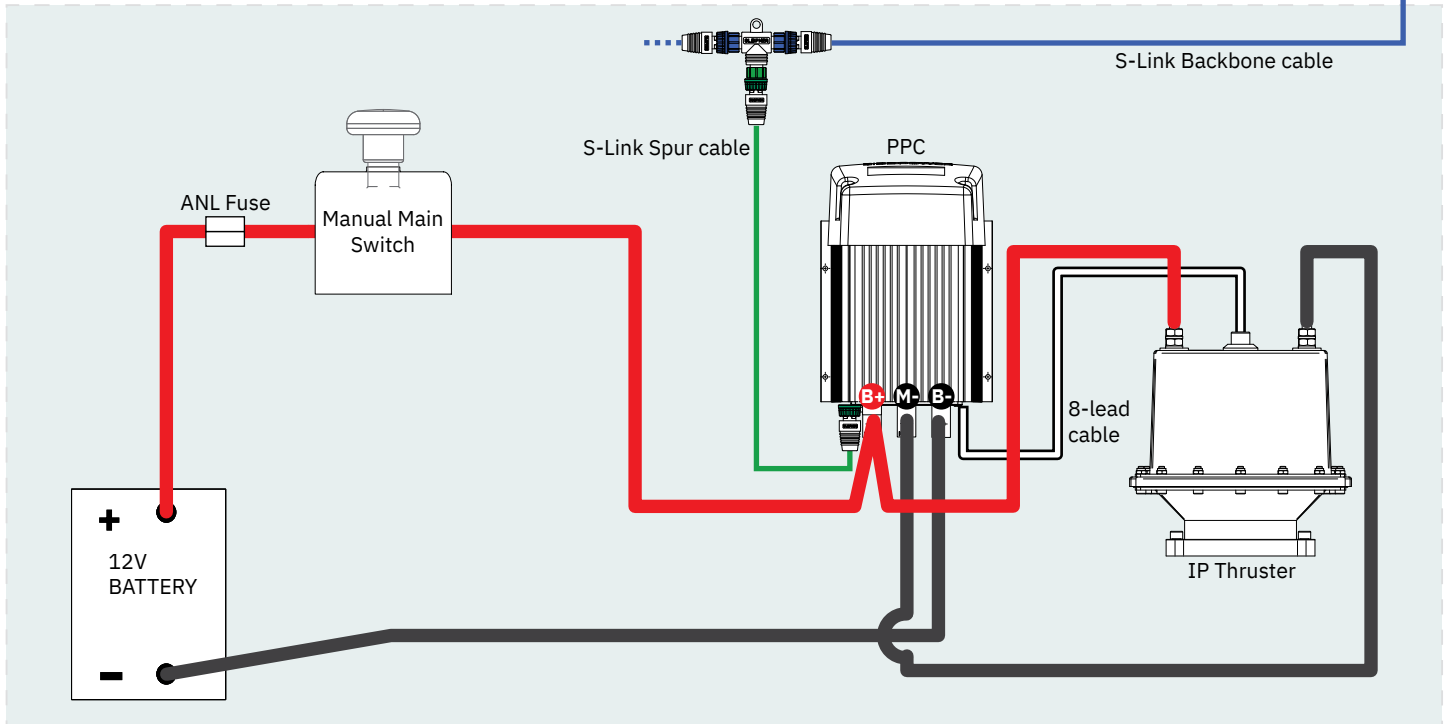

MG_0597

Automatic Main Switch Wiring Diagram 12V S-Link IP Thruster

The Top wiring setup is for a single bow OR stern thruster system

See S-Link System Description chapter for detailed information on installation of S-Link POWER Cable, END Terminator and additional S-Link components.

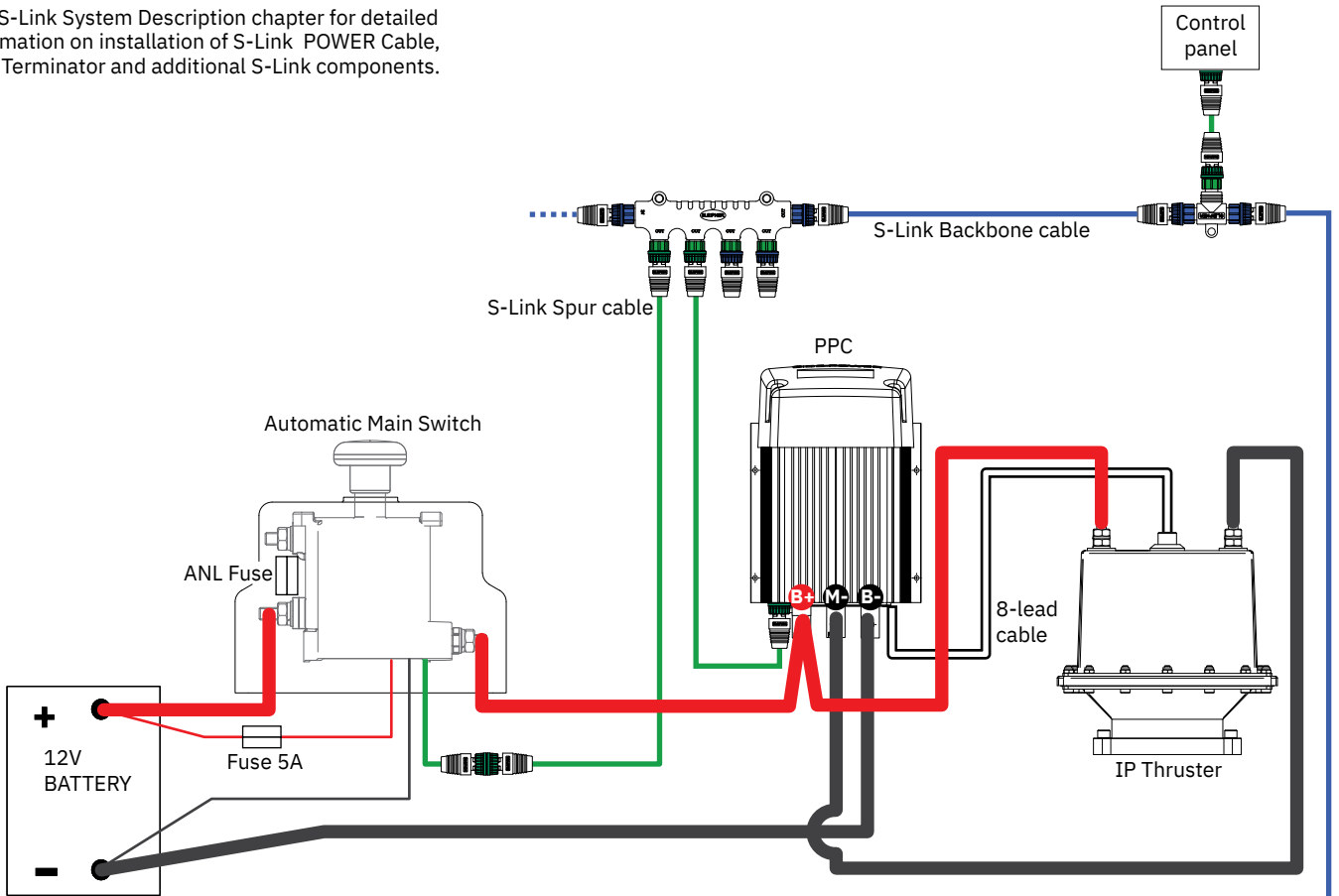

The top and bottom wiring setup is for a dual thruster system, For example bow and stern.

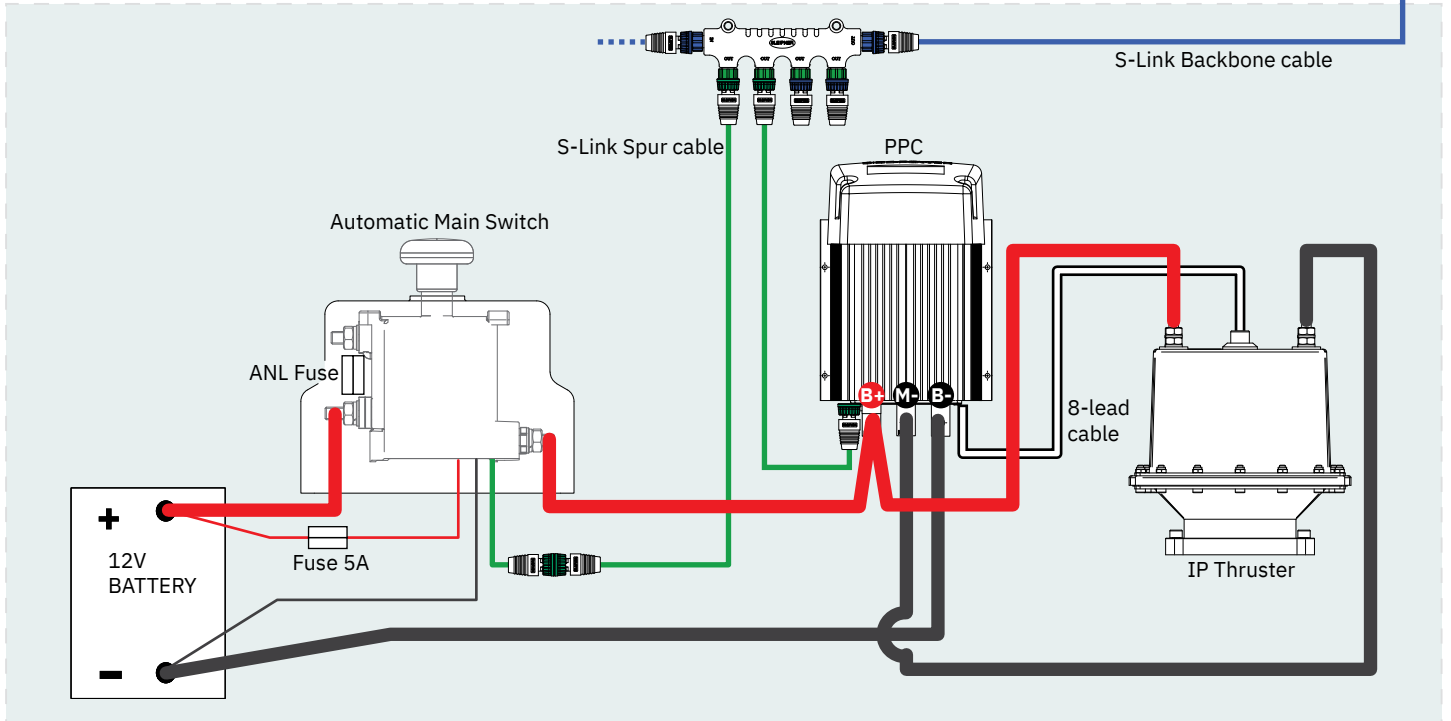

MG_0560

For **Control Panel** installation please refer to the Installation Guide accompanying the control panel to be installed.



- The bolts holding the gear leg and main bracket together are tightened correctly.
- The bolts holding the motor to its bracket are tightened correctly.
- All electrical connections are clean, dry and tight, and the correct cable, fuse and main switch size.
- Check that there is no electrical connection between the electro motor body and positive terminal on the motor, and between the electro motor body and the negative terminal on the motor with an ohm meter.
- Anti-fouling has been applied to the gear leg and propeller but NOT anodes, sealing/ rubber fittings or propeller shafts.
- Propeller is fastened correctly to the shaft.
- Propeller turns freely in tunnel.
- The anode and/ or holding screw is tightened well with thread glue.
- Check the boat for potential water leakage around installation areas.
- Correct drive direction as per control panel.
- User Manual is supplied to the owner.

The thruster has been installed as per the instructions in this manual and all points in checklist above have been controlled.

Signed:

Date:

Thruster type:

Serial number:.....

Date of delivery:.....

Correct drive direction as per control panel:

The compartment for the thruster has been isolated from general bilge water and has no obvious or suspected risks for flooding:

.....
.....
.....

Other comments by installer:

.....
.....

Find your local professional dealer from our certified worldwide network for expert service and support. visit our website www.sleipnergrouper.com/support

Product Spare Parts and Additional Resources

For additional supporting documentation, we advise you to visit our website www.sleipnergrouper.com and find your Sleipner product.

Warranty statement

1. Sleipner Motor AS (The “Warrantor”) warrants that the equipment (parts, materials, and embedded software of products) manufactured by the Warrantor is free from defects in workmanship and materials for purpose for which the equipment is intended and under normal use and maintenance service (the “Warranty”).
2. This Warranty is in effect for two years (Leisure Use) or one year (Commercial and other Non-leisure Use) from the date of delivery/purchase by the end user, with the following exceptions;
 - (a) For demonstration vessels, or vessels kept on the water, the dealer is considered as the end user from 6 months after their launch of the vessel;
 - (b) The warranty period starts no later than 18 months after the first launch of the vessel.
 Please note that the boat manufacturer and dealer must pay particular attention to correct maintenance and service both by the products manuals as well as general good practice for the location the boat is kept in the period the boat is in their care. In cases where the 6 and 18 months grace periods for boat builders and dealers are passed, it is possible to obtain a full warranty upon inspection and approval of the warrantor or such representative.
3. Certain parts, classified as wearable or service parts, are not covered by the warranty. A failure to follow the required maintenance and service work as described in the product manual render all warranty on parts or components directly or indirectly affected by this void. Please also note that for some parts, time is also a factor separately from actual operational hours.
4. This Warranty is transferable and covers the equipment for the specified warranty period.
5. The warranty does not apply to defects or damages caused by faulty installation or hook-up, abuse or misuse of the equipment including exposure to excessive heat, salt or fresh water spray, or water immersion except for equipment specifically designed as waterproof.
6. In case the equipment seems to be defective, the warranty holder (the “Claimant”) must do the following to make a claim:
 - (a) Contact the dealer or service centre where the equipment was purchased and make the claim. Alternatively, the Claimant can make the claim to a dealer or service centre found at www.sleipnergrouper.com. The Claimant must present a detailed written statement of the nature and circumstances of the defect, to the best of the Claimant’s knowledge, including product identification and serial nbr., the date and place of purchase and the name and address of the installer. Proof of purchase date should be included with the claim, to verify that the warranty period has not expired;
 - (b) Make the equipment available for troubleshooting and repair, with direct and workable access, including dismantling of furnishings or similar, if any, either at the premises of the Warrantor or an authorised service representative approved by the Warrantor. Equipment can only be returned to the Warrantor or an authorised service representative for repair following a pre-approval by the Warrantor’s Help Desk and if so, with the Return Authorisation Number visible postage/shipping prepaid and at the expense of the Claimant.
7. Examination and handling of the warranty claim:
 - (a) If upon the Warrantor’s or authorised service Representative’s examination, the defect is determined to result from defective material or workmanship in the warranty period, the equipment will be repaired or replaced at the Warrantor’s option without charge, and returned to the Purchaser at the Warrantor’s expense. If, on the other hand, the claim is determined to result from circumstances such as described in section 4 above or a result of wear and tear exceeding that for which the equipment is intended (e.g. commercial use of equipment intended for leisure use), the costs for the troubleshooting and repair shall be borne by the Claimant;
 - (b) No refund of the purchase price will be granted to the Claimant, unless the Warrantor is unable to remedy the defect after having a reasonable number of opportunities to do so. In the event that attempts to remedy the defect have failed, the Claimant may claim a refund of the purchase price, provided that the Claimant submits a statement in writing from a professional boating equipment supplier that the installation instructions of the Installation and Operation Manual have been complied with and that the defect remains.
8. Warranty service shall be performed only by the Warrantor, or an authorised service representative, and any attempt to remedy the defect by anyone else shall render this warranty void.
9. No other warranty is given beyond those described above, implied or otherwise, including any implied warranty of merchantability, fitness for a particular purpose other than the purpose for which the equipment is intended, and any other obligations on the part of the Warrantor or its employees and representatives.
10. There shall be no responsibility or liability whatsoever on the part of the Warrantor or its employees and representatives based on this Warranty for injury to any person or persons, or damage to property, loss of income or profit, or any other incidental, consequential or resulting damage or cost claimed to have been incurred through the use or sale of the equipment, including any possible failure or malfunction of the equipment or damages arising from collision with other vessels or objects.
11. This warranty gives you specific legal rights, and you may also have other rights which vary from country to country.

Patents

At Sleipner we continually reinvest to develop and offer the latest technology in marine advancements. To see the many unique designs we have patented visit our website www.sleipnergrouper.com/patents

© **Sleipner Group**, All rights reserved
The information given in the document was right at the time it was published. However, Sleipner Group cannot accept liability for any inaccuracies or omissions it may contain. Continuous product improvement may change the product specifications without notice. Therefore, Sleipner Group cannot accept liability for any possible differences between product and document.

Learn more about our products at
www.sleipnergroun.com



SLEIPNER GROUP

P.O. Box 519

N-1612 Fredrikstad

Norway

www.sleipnergroun.com

Made in Norway

